

Follow-up Copy



September 29, 1978

GTE Sylvania
Electronic Components Group
Circuit Module Operation
P.O. Box 360
Muncy, PA 17756
Attn: John Robinson

General Instrument Corp.
Microelectronics Division
600 W. John St.
Hicksville, NY 11802
Attn: Ken Greenburg

SUBJ: Mattel/Sylvania/General Instrument Meeting, held
on 9-27-78, concerning Intellivision (Video).

The following representatives were present:

<u>MATTEL</u>	<u>GTE SYLVANIA</u>	<u>GENERAL INSTRUMENT</u>
— Dave Chandler	Rusk Smith	Ken Greenburg
Fred Held	Tom Gouldy	
Howard Cohen		
Bob Cowell		
Gerry Foard		
Dolfe Lee		
Chi Wang		
Jeff Rochlis		
Denny Bogart		

The following represents key comments and next steps to be taken:

- 1) G.I. supply temperature and duty cycle specs (for static "burn-in") to Sylvania by 10/2.
- 2) Rough draft of contract from Sylvania due week of 10/2.
- 3) Sylvania to identify logic board connector or lack of availability of one by 10/4 (10 pin, 5 position, 2 sided, right angle).
- 4) G.I. supplies sample boards to Mattel by 10/9.
- 5) G.I. to supply first revision of P.O.B. by 11/1, could possibly have 2 or 3 more revisions.
- 6) Possibility of fan addition in console - decision by Mattel could be late as Jan. 1979 (Dave Chandler).
- 7) Mattel will design shielding plus obtain sample parts by 11/1 (Dave Chandler).

- 8) ^{duplicate} Mattel will design shielding plus obtain sample parts by 11/1 (Dave Chandler).
- 9) Mattel supply part and mold drawings to Sylvania by 9/28 (Denny Bogart)
- 10) Mattel plans to initiate contract negotiations at Sylvania on 10/9 - 10/10 or shortly thereafter (Howard Cohen).
- 11) Design specs/inspection criteria due from Mattel by 12/22 (Dolfe Lee).
- 12) G.I. Testing - All components are programmed on Sentry 7 equipment (to check yield improvement). G.I. will not test all chips on Sentry 7, they will convert to custom equipment once they are in production. G.I. will conduct 3 tests (2 100% and 1 sample test). A hot chuck test at 40°C at wafer level. Assemble in packages and 100% test again. The first 1,000 to 5,000 chips will be "in sets" - Lots will then be shipped in to Sylvania according to AQL. Sample lots will be kitted, after first 1,000 to 5,000, and tested with documentation being sent to Sylvania.
- 13) G.I. will design and build 1 tester (Go/No go) by 2/1 .
- 14) "Burn in" Definitions:
Dead - Cycle through temperature
Live - Chips in functional mode
Final - In assembled unit
- 15) Sylvania to obtain socket leadtime and quotes, furnished to Howard Cohen by 10/16. Mattel will decide upon quantity and exposure for parts past initial 2 months.
- 16) Color code pilot quantities of boards (G.I.). G.I. to purchase 50 boards.
- 17) P.C.B. - G.I. will turnover artwork to Sylvania.
- 18) P.C.B. - Sylvania is quoting 14-16 weeks to production.
- 19) Chips - G.I. is quoting 6-8 weeks after approval until production.
- 20) Mattel offered to place purchase order to G.I.'s vendor on P.C.B.s to cover first 250 units plus first months production.

- 21) Mattel will purchase and own test equipment and contractually supply to assembly vendor, as necessary.
- 22) Sylvania to quote "burn in" on components separately from final system.
- 23) G.I. to quote "burn in" before their final 100% test.
- 24) Workmanship specs supplied to Mattel on 9/27. Dolfe Lee to approve by 10/11.
- 25) Product Spec - will require continual update by Mattel (Dolfe Lee). Dolfe Lee to breakout and separate mechanical and electronic data contained in product spec plus, final test exclusive of G.I. functional test.
- 26) G.I. - to supply STIC II 2nd emulator by 10/6.
- 27) Schedule:

250 Unit Pilot "Burn in" 168 hours
4-6 weeks debug

PRODUCTION

50 a day 1st week = 250 "Burn in" 168 hours
75 a day 2nd week = 375 "Burn in" 48 hours
125 a day 3rd week = 625 (Target rest of production
200 a day 4th week = 1000 for less than a shift)
300 a day 5th week = 1500 Sylvania wants parts in hand
500 a day 6th week = 2500 for week #8.
750 a day 7th week = 3750
1000 a day 8th week = 5000

} 2 Special Proof run of 50 units for ea week 2-3-4.

MAX 4000 a day
Sylvania would like chips delivered 6 weeks ahead during Production.

- 28) Sylvania to build 45 units in Dec., to be covered by a separate P.O.. There will also be a P.O. for component parts to supply G.I. and Sylvania for F.C.C. and show sample system assembly.
- 29) All drawings/specs submitted to Mattel for approval shall become Mattel property who will then issue to appropriate sources.
- 30) Mattel - clean up (44 pin cartridge and hand controller) connector drawing and issue.

- 31) All correspondence for this product will flow through the following People: General Instrument - Ken Greenburg, GTE Sylvania - John Robinson, Mattel - Denny Bodart in addition to the normal people you interface with.
- 32) Mattel - update parts list and cross reference components (Bob Cowell).
- 33) G.I. - will build 6 units to cover FCC etc.
- 34) Serialize and document all production.
- 35) Procurement of 50 units components - Sylvania to review Bill of Materials and notify Mattel for assistance on difficult parts.
- 36) Sylvania to use G.I. memo dated 9/22 for P.C. Board components for quotation.
- done 10-3-78* 37) Mattel furnish updated inter connect drawing to G.I. and Sylvania.
- 38) Schedule: First 8 weeks

<u>Units</u>	<u>Week Ending</u>	<u>CUM</u>
250	1/26/79	250
250	2/23/79	500
375	3/2/79	875
625	3/9/79	1500
1000	3/16/79	2500
1500	3/23/79	4000
2500	3/30/79	6500
3750	4/6/79	10,250
5000	4/13/79	15,250

cc: Josh Denham
Jim Kingsbury
Kent Wall
Ralph Stewart
Steve Nelson
Marilynn Woodford

October 19, 1978

Mattel Incorporated
Mattel Toy Division
5750 Rosecrans Avenue
Hawthorne, California 90250

Attention: Mr. Howard L. Cohen, Director of Purchasing

Subject: OUTSTANDING INFORMATION REQUIREMENTS

Dear Howard,

The following is a listing of outstanding items for which we urgently need information:

1. GI was to have supplied temp. and duty cycle information re temp. cycling of special chips for which you requested our quote. We have not received this info as yet. You were going to investigate if there is still a need per Messrs. Chandler and Greenberg conversation.
2. A burn-in program and specification for the final assembly was to have been available by 10/6/78. We have not received as yet.
3. Workmanship specifications must be received from Mattel ASAP.
4. GI was to have advised their maximum running rates for Chips by 10/2. They now advise that their maximum running rates are confidential and they will not supply. We must have assurance that our schedule will be amply supported.
5. Will UL logo be molded in plastic housing or are separate labels going to be required? Will UL identification be required on first 50 units?
6. You advised that Mattel would supply all plastic parts, labels, instruction sheets etc. for the requirement of 50 units (we are assuming we will in turn furnish these items to GI for their six (6) unit build). Please advise when this material will be shipped.
7. We will provide all components for cartridge assemblies. Our understanding is that only the six special game chips will be consigned. Please confirm and identify consigned I.C.'s.
8. The cartridge connector P/N 2609-9399 on logic board assembly cannot be identified by Methode. We need to know Methode's part number to buy and an individual at Methode that can be contacted.

I'm doing temp check + soak, some concern, but lets start that way!

done in here. Records in Dennis' minutes

*?
We have ordered for 50 systems*

*186-413-01 w/44 contact
John Klinek - 312-867-9600
Rex McDonald - R.H. McDonald Assoc
213-349-7911*

9. We are buying Transformer Assembly #2609-9849 from Midwest. We urgently need drawings and specifications for this special component.

You should note that lead time for production quantities are being quoted in excess of 22 weeks.

10. Our understanding, using the Circuit Assembly Corp. connector #CA10314/10315 at the hand controller end and a nine (9) conductor cable from Victor results in one (1) unused contact at the logic board connector. Please confirm.

11. Antenna Switch assemblies are not identified. We are providing Artec switch P/N Q76-124 and Artec antenna cable P/N W211170.

12. P.C. Boards for 50 prototypes will be provided by G.J. We require Mattel's definition for color coding of prototypes to avoid later innermixing with production units.

13. Parts List shows four Pots. (R24, 25, 28 and 29) but lists no values; and shows nine (9) Carbon Film Resistors (R3, 6, 15, 16, 20, 21, 22, 26 and 27) but lists no values. Please advise.

14. Cricket Switches we have received are CTS Part No. C-1690A, we need verification they are the correct switches.

15. We cannot identify "Washer, push-on" or "Compression Spring" P/N 0405-4279 on parts list. Please advise.

16. The following listed parts must be provided by Mattel for the first 50 unit requirements.

PARTS REQUIRED FROM MATTEL FOR 50 UNITS

<u>Part No.</u>	<u>Description</u>	<u>Qty. Per</u>	<u>Total Req'd.</u>
2609-0920	Master Carton	1/5	5
2609-0810	End Cap	2	100
0001-5270	Poly. Bag	1	50
2609-0920	Instruction Sheet	1	50
09-260929	Chip Board for Cartridge	1	50
2610-0970	Carton	1	50
2609-0970	Label	1	50
2610-2129	Base	1	50

?
 delayed
 11/1/78

yes,
 when you spec
 on connectors?

Send specs

Pick one

Mattel Incorporated
 Mattel Toy Division
 Mr. Howard L. Cohen

October 19, 1978
 Page 3

PARTS REQUIRED FROM MATTEL FOR 56 UNITS - CONT'D.

<u>Part No.</u>	<u>Description</u>	<u>Qty. Per</u>	<u>Total Req'd.</u>
- 2610-2139	Lid	1	56
2610-2259	Packing Piece	1	56
2610-0920	Instruction Book	1	56
2610-4289	Program Guide	2	112
GI K03-8503	IC	1	56
2610-2040	Housing	1	56
2610-0340	Label	1	56
2610-9529	Access Panel	1	56
0405-0842	Screw 6-20 x 7/16	2	112
GI AYS-6910	IC	1	56
GI 13-260980	P/C Board - Cartridge	1	56
GI K03-9874	IC 5071	2	112
- 2608-2105	Console Base	1	56
- 2608-2042	Tray	1	56
GI 0413-9500	IC	1	56
0408-0822	Screw 6-18 x 1/2	2	112
- 2608-2104	Reset Button	1	56
- 2608-2138	Glossy Cap	1	56
01-260982	Washer - Push-on	1	56
GI 5112-0338	IC	1	56
- 2611-0370	Label	1	56
- 2608-0370	Label	1	56
- 2608-0330	Label	1	56
- 2608-2114	Console Cover	1	56
- 2608-0388	Conn. 44 Pin	1	56
- 2608-2084	Housing Lower	2	112
- 2608-9888	Circuit Matrix	2	112
- 2608-2095	Push Button	2	112
0401-0867	Screw 6-20 x 7/16	2	112
47-260874	RF Shield - Upper	1	56
0402-4279	Compression Spring	1	56
- 2608-2060	Housing Upper	1	56
- 2608-2070	Frame	1	56
- 2608-2080	Control Disc	2	112
47-260925	RF Shield - Lower	1	56
- 2608-0810	Control Disc Inlay	2	112
GI 13-260940	P/C Bd. Power Supply	1	56
GI 13-260923	P/C Bd. Logic	1	56
GI K03-8502	IC	1	56
GI K018-8808	IC	1	56
GI 443-5700	IC	1	56
GI 0P1610	IC	1	56

Your prompt attention in this matter will be sincerely appreciated.

~~Page 2~~

2. Frequency of testing — Allowance

3. — Self Lee

4. — confirm requested rates

* 7. — Hummer

9. fuse - long lead,

* 12. Self Lee

14.

15.

~~centrally spring~~
during doing

centrally spring
Reset switch washer

#3

11-15

#10

- get CAA duct to Sylvane

Antenna cable

RG-59

Burn-in test intervals

220

Neotank Shennalloy 607.1B

Supply CAA

5:00 out ^{network} to Williamsport - Ramada

~~4:00~~

This morning

Send requested change in addressing to Ken G.

10-2-78

D. P. CHANDLER

REV. 10-11-78

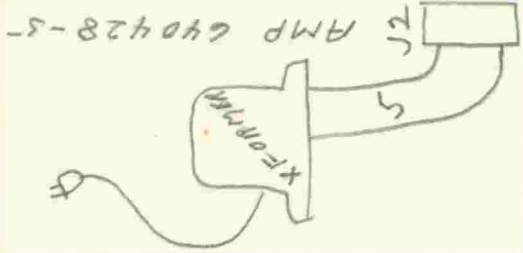

AMP 640383-5

AMP 640383-6

AMP 640428-6

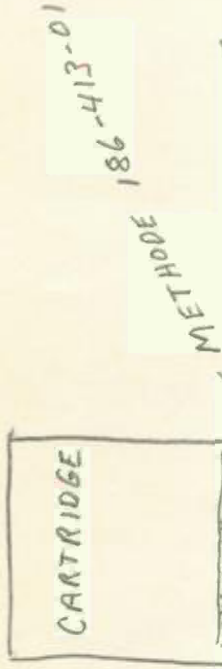

186-413-01

METHODE

J6 -- RCA SOCKET

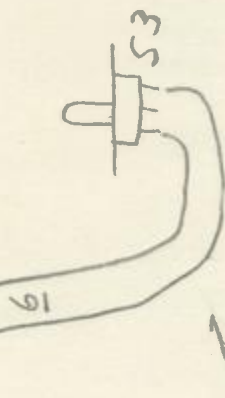
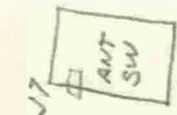
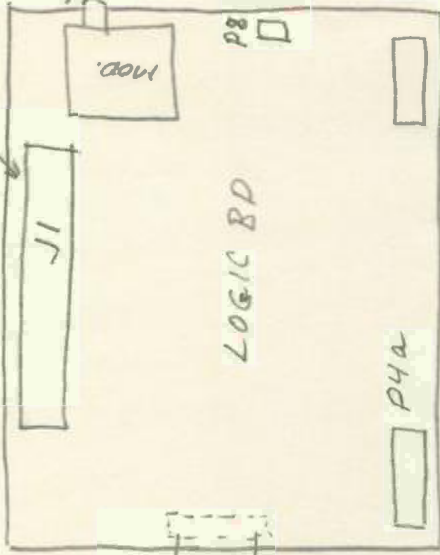
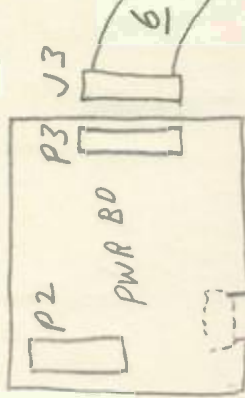

S3- UID/AMF SW432-SD-L0-S-81-UK 9

P4B EDGE FINGERS OR
AMP 640099-9

J4 5 POSITION, 10 CONTACT EDGE
CONNECTOR OR
AMP 640443-9

J5 CIRCUIT ASSEMBLY
CA-10314/CA-10315

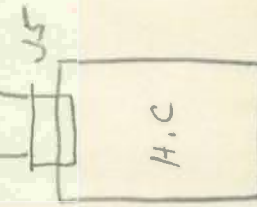
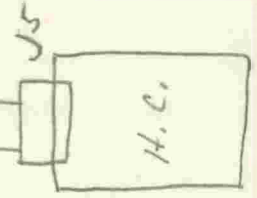

* DESIGNATES PARTS TO BE OBTAINED BY
 PENNSYLVANIA FOR FIRST 50 SYSTEMS

10-2-78

MATTEL VIDEO GAME SYSTEM

REV 10-4-78

PARTS LIST

LOGIC BOARD:

DESIGNATION	P/N	DESCRIPTION	SOURCE
IC1	CP 1610	Microprocessor	G.I.
IC2	RA-3-9600	RAM	G.I.
IC3	RO-3-9504	20K ROM	G.I.
IC4	AY-3-8900	STIC	G.I.
IC5	RO-3-9503	16K ROM	G.I.
IC6	AY-3-8910	PSG	G.I.
* IC7, IC8, IC12	3539	256 X 8 RAM	EMM-Semi
IC9	RO-3-9502	20K ROM	G.I.
IC10	AY-3-8915	Color	G.I.
* IC11	7406	Hex Inverter	G.I.
Q1, Q2	2N3906	Transistor	
D1	IN4001	Diode	
R1, R5,	1K	1/2 W Resistor	10%
R2	47 Ω	1/2 W Resistor	"
R3, R6, R15	TBD	1/2 W Resistor	"
R19, R20, R21	TBD	1/2 W Resistor	"
R22, R26, R27	TBD	1/2 W Resistor	"
R4	380 Ω	1/2 W Resistor	"
R7, R8	3.3K	1/2 W Resistor	"
R9	560 Ω	1/2 W Resistor	"
R10	10K	1/2 W Resistor	"
R11	100 Ω	1/2 W Resistor	"
R13, R14, R23	10 Ω	1/2 W Resistor	"
R16	470 Ω	1/2 W Resistor	"
R17	2.2K	1/2 W Resistor	"
R18	200K	1/2 W Resistor	"
R24, R25, R28	TBD	Trim Potentiometer	
R29			
XTAL	3.579MHz	Crystal	
RFX	Um1285	Modulator	Astec
C1	20 pf	Capacitor	
C2	5-50 pf	Trim cap	
C4-C22, C24	.1 μ F	Cap.	
C25	100 pf	Cap.	
C26, C3	1 μ f	Cap.	
C27, C28, C30,	10 μ f	Tant. Cap.	
C31	.01 μ f	Cap.	
S1	SPST - C1690A	Switch	CTS of Eikhart
S2	SPDT	Switch	S1012-SD-T-D-P-BI-EK-CE UID/AMF
P1		Connector	
P2 P7		Connector	
P3 P40 } EDGE FINGERS OR		Connector	
* P4b } AMP 640099-9		Connector	
J1	186-413-01	Connector	AMP
* J2 J3	640428-6	Connector	METHODE AMP



MICROELECTRONICS DIVISION
 GENERAL INSTRUMENT CORP.
 HICKSVILLE, NEW YORK 11802

SPECIFICATION NO.

DRAWING NO. 39-147

REV.

SHEET 1 of 3

B

LOGIC BOARD (con't)

<u>DESIGNATION</u>	<u>P/N</u>	<u>DESCRIPTION</u>	<u>SOURCE</u>
* IC 13	74LS08	Quad. and Gate	
IC 14, IC 15	74LS126	Quad. Tri-state buffer	
Q3	2N3904	Transistor	
* R30	150	1/4 W resistor	



MICROELECTRONICS DIVISION
 GENERAL INSTRUMENT CORP.
 HICKSVILLE, NEW YORK 11802

SPECIFICATION NO.

SHEET 2 of 3

REV.
 B

MATTEL VIDEO GAME SYSTEM
PARTS LIST (con't)

POWER SUPPLY BOARD:

DESIGNATION	P/N	DESCRIPTION	SOURCE
* J3	SW432-S.D-LO-S-81-JK	SWITCH	UID/AMF
IC1	uA 7805	5V regulator	
IC2	uA 7812	12V regulator	
O1-D8	IN4001	Diode	
D9	IN746A	3.3V Zener Diode	
C1	10000 uf	16V Cap.	
C2	100 uf	5V Cap.	NICHICON
C4, C5, C6	.1 uf	Cap.	
R1	220 Ω	$\frac{1}{2}$ Watt Resistor	
C3	1000 uf	25V Cap.	
P2	640383-5	Connector	AMP
* P3	640383-6	Connector	AMP

CARTRIDGE BOARD:

* IC1, IC2	RO-3-9504	20K ROM	G.I.
* C1	.1 uf	Cap.	

TRANSFORMER ASSY:

* J2	640428-5	CONNECTOR	AMP
------	----------	-----------	-----

HAND CONTROLLER: (2 PER SYSTEM)

* J4	10 PIN EDGE OR AMP 640443-9	CONNECTOR	AMP
------	--------------------------------	-----------	-----

FAN ASSY:

* J7		CONNECTOR	
------	--	-----------	--

* ANTENNA CABLE

* ANTENNA SWITCH

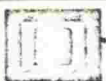

MICROELECTRONICS DIVISION
GENERAL INSTRUMENT CORP.
HICKSVILLE, NEW YORK 11502

SPECIFICATION NO.

REV.

SHEET 3 of 3

B

KG 9/22/78

Form IE102

CONFIDENTIAL

TOY NO. 2609-9991 (1978)

TOY NAME VIDEO GAME (1978)

Chg. Ltr	PART NUMBER	S I Z E	NUMBER REQUIRED NEXT ASSEMBLY						TOTAL TOY	PART DESCRIPTION	DESCRIPTION	UNIT OF MEAS.	SOURCE	PR CL
			1	2	3	4	5	6						
	2609-9991		1							VIDEO GAME				
	2609-9109			1					-	CONSOLE ASSEMBLY ..				
	2609-2109					1			1	Console Base	A.B.S.	ea		3
	2609-9519					1			1	Circuit Board Assembly #1		ea		3
	2609-2149					1			1	Tray	A.B.S.	ea		3
	0405-0802					6			6	Screw (8-18 X 1")	Shakeproof Hi-Lo	ea		1
	2609-9539					1			1	Power Supply Board Assembly		ea		3
	0405-0812					6			6	Screw (8-18 X 1/2")	Shakeproof Hi-Lo	ea		1
	2609-9549					1			1	Transformer Assembly		ea		3
	2609-9559					1			1	Slide Switch Assembly		ea		3
	0405-0822					2			2	Screw (6-19 X 1/2")	Shakeproof Hi-Lo	ea		1
						1			1	Shield R.F. Upper				
						1			1	Shield R.F. Lower				
	2609-0230					1			1	Insulator		ea		3
	2609-9489					4			4	Foot - Adhesive	3M SJ-5112	ea		3

replacement on PE Board only

NUMBER	Ltr. Cha.	REVISION	APD	DATE
		INITIAL RELEASE of -9991		MAR 13 1978

CONFIDENTIAL

NO. 2609-9991 (1978)

TOY NAME VIDEO GAME (1978)

Chg. Ltr	PART NUMBER	S I Z E	NUMBER REQUIRED NEXT ASSEMBLY						T O T A L	PART DESCRIPTION	DESCRIPTION	UNIT OF MEAS.	SOURCE	PR CL
			1	2	3	4	5	6						
	2609-9119				1				-	Console Cover - labeled		ea		3
	2609-0320					1			1	Label - plain	foil	ea		3
	2609-0330					1			1	Label - controls	foil	ea		3
	2609-6119					1			-	Console Cover - Painted		ea		3
							AR		AR	paint		gal		
	2609-2119							1	1	Console Cover	A.B.S.	ea		3
	0405-0832				6				6	Screw (8-18 X 3/4")	Shakeproof Hi-Lo	ea		1
	2609-2129				1				1	Button - Reset	A.B.S.	ea		3
	2609-4269				1				1	Spring-Push Button	Magnavox P/N733305-1	ea		3
	0405-0812				1				1	Pushnut Fastener	Walnut PD156007	ea		1
	2609-2139				1				1	Glamour Cap	A.B.S.	ea		3
	2609-9599				1				1	Cable - Antenna	461218-6	ea		3
	2609-9609				1				1	Switch Unit Assembly-Antenna		ea		3

NUMBER	REV. Chg.	REVISION	APD	DATE
		INITIAL RELEASE of -9991		MAR 13 1978

CONFIDENTIAL

TOY NO. 2609-9991 (1978)

TOY NAME VIDEO GAME (1978)

Chg. Ltr	PART NUMBER	SIZE	NUMBER REQUIRED NEXT ASSEMBLY						TOTAL TOY	PART DESCRIPTION	DESCRIPTION	UNIT OF MEAS.	SOURCE	PR CL
			1	2	3	4	5	6						
	2609-9059				2				-	HAND CONTROLLER ASSEMBLY		ea		3
	2609-9579					1			2	Cable-Assembly (w/connectors)		ea		3
	2609-9569						1		2	Cable		ea		3
	2609-9469						1		2	Connector - Controller		ea		3
	2609-9479						1		2	Connector - Console		ea		3
	2609-2059	E				1			2	Housing, Lower	A.B.S.	ea		3
	2609-9589						1		2	Circuit Matrix	Chomerics	ea		3
	2609-2099	C				2	4		P	Push Buttons	polyeth.	ea		3
	2609-9089					1			2	Disc - Control w/inlay		ea		3
	2609-2089	B					1		2	Disc - Control	acetal	ea		3
	2609-0310						1		2	Inlay	foil	ea		3
	2609-9069					1			-	Housing-Upper Sub Assembly		ea		3
	2609-2069	E					1		1	Housing - upper	A.B.S.	ea		3
	2609-2079	C				1			1	Frame	A.B.S.	ea		3
	0405-0842						4		8	Screw (5-20X 7/16")	Shakeproof Hi-Lo	ea		1

NUMBER	Ltr. Chg.	REVISION	APD	DATE
- 3	I	INITIAL RELEASE of -9991	gf	3/13/78
	a	cancel page 4 to delete 2609-9039 Cassette Assy. & details		MAY 2 1978

CONFIDENTIAL

TOY NO. 2609-9993, -9992 (1977)

TOY NAME VIDEO GAME

Chg. Ltr	PART NUMBER	SIZE	NUMBER REQUIRED NEXT ASSEMBLY						TOTAL TOY	PART DESCRIPTION	DESCRIPTION	UNIT OF MEAS.	SOURCE	PR CL
			1	2	3	4	5	6						
	2609-9993	-	1						-	STANDARD PACK (1978)				
	2609-0930	B		1					1/6	master carton	corrug.	ea		3
	0405-0790	A		AR					AR	tape	3" reinf.	yd		1
	2609-9992	-		6					1	toy in individual labelled carton		ea		3
	2609-9992	-		1					-	TOY IN INDIVIDUAL LABELLED CARTON				
	2609-9219	-			1				-	individual carton - labelled		ea		3
	2609-0910	B				1			1	individual carton		ea		3
	2609-0970	A				1			1	label	pr. paper	ea		3
	0405-9950	A			AR				AR	tape*	2" clear	yd		1
	2609-0810	D			2				2	end cap	styro bead	ea		3
	0405-0290	A			AR				AR	tape	1" clear	yd		1
	0001-9210	A			1				1	poly sleeve (11-1/2 X 24)	polyeth	ea		1
	2609-0920				1				1	instruction sheet	pr. paper	ea		1
	2610-9991	-			1				1	Football Cassette		ea		1
	2609-9991	-			1				1	VIDEO GAME		ea		3

*NOTE: glue (3220-1740) or staples (0405-0620) may be used as an alternate

NUMBER	Ltr. Chg.	REVISION	APD	DATE
-2		INITIAL RELEASE of -9993, -9992		PR-12 1978

CONFIDENTIAL

TOY NO. 2610-9991 (1978)

TOY NAME FOOTBALL VIDEO CASSETTE (1978)

Chg. Ltr	PART NUMBER	SIZE	NUMBER REQUIRED NEXT ASSEMBLY						TOTAL TOY	PART DESCRIPTION	DESCRIPTION	UNIT OF MEAS.	SOURCE	PR CL
			1	2	3	4	5	6						
	2610-9991	-	1						-	FOOTBALL CASSETTE W/CASE				
	2610-9039	-		1					-	CASSETTE ASSEMBLY		ea		3
	2610-9049	-			1				-	housing - labelled		ea		3
	2610-0340					1			1	label	foil	ea		3
	2610-2049					1			1	housing	styrene	ea		1
	2610-9389				1				1	circuit board assembly		ea		3
	2610-9529				1				1	panel - access	styrene	ea		1
	0405-0842				2				2	screw (5-20x7/16")		ea		1
	2610-2129			1					1	base - cassette case	acrylic	ea		1
	2610-2139			1					1	lid - cassette case	acrylic	ea		1
	2610-2259			1					1	packing piece	polyureth.	ea		1
	2610-0920			1					1	instruction booklet	pr. paper	ea		3
	2610-4289			2					2	program guide	mylar	ea		3
	2610-4384				1					P.C. BOARD CASSETTE				
					1					IC CARTRIDGE ROM	IC 13			
					1					IC CARTRIDGE ROM	IC 14			
					2					0.1 uF CAPACITORS				

NUMBER	Ltr. Chg.	REVISION	APD	DATE
2610-4		INITIAL RELEASE of -9991		APR 1 8 1978

CIRCUIT BOARD ASSEMBLY #1

TOY NUMBER 2609

PART DESCRIPTION	U S A G E	C D	N E W P A R T	U N I T O F	M E A S U R E	0001			
						UNIT	DEC	UNIT	DEC
SWITCH SLIDE CHANNEL SELECT \$ S2				EA		100			
SWITCH MOMENTARY \$ S1				EA		100			
SWITCH MOMENTARY \$ S1				EA		100			
CONV MDL 5 PIN MLE \$ J5				EA		100			
SOCKET IC				EA		100			
IC SOCKET (24) PIN				N	EA	500			
WAFER ASSEM CONT CABLE \$				N	EA	200			
J3,4									
WAFER ASSEM CONT CABLE \$				N	EA	200			
J3,4									
CONNECTOR 22 PIN \$ J1				N	EA	100			
PC 80 LOGIC				N	EA	100			
RCF 330 OHM 5.5W \$ R4					EA	100			
RCF 10 OHM 5 .25W \$ R13					EA	100			
RCF 1K OHM 5 .25W \$ R3,5					EA	200			
RCF 10K OHM 5 .25W \$ R10					EA	100			
RCF 1MEG 5.25W \$ R5					EA	100			
RCF 27 OHMS 5.25W \$ R2					EA	100			
RCF 3.3K OHM 5.25W \$ R7,8					EA	200			
RCF 470 OHM 5.25W \$ R11					EA	100			
RCF 560 OHM 5 .25W \$ R9					EA	100			
CAPC 20PF 5 NPD 500V \$ C1			2		EA	100			
CAPPY .1 MFD 20 100V \$					EA	500			
C3,4,5,6,7									
CAPC TRIMMER 50PF \$ C2					EA	100			
CAPE 10MFD 35V \$ C10					EA	100			
CRYSTAL PIEZO \$ X1					EA	100			
TRANSISTOR SIL \$ Q3					EA	100			
IC QUAD INP P GATE \$ IC11					EA	100			
IC 6810 STATIC RAM \$ IC13				N	EA	100			
IC STIC AY3-8900-1 \$ IC4				N	EA	100			
IC CP 1610X MPC \$ IC1				N	EA	100			
IC 20K ROM \$ IC3				N	EA	100			
IC GRAPHICS ROM \$ IC5				N	EA	100			
IC SOUND - I/O \$ IC6				N	EA	100			
IC RA-3-9600 RAM \$ IC2				N	EA	100			
IC 2112 ASTATIC RA \$ IC7,8,9,10				N	EA	400			
IC 7407 TTL BUFFER \$ IC12				N	EA	100			
MODULATOR VHF				N	EA	100			
INFORMATION FOR PJ7708				XX		100			
IC SOCKET 16 PIN DIP				EA		50			
IC SOCKET 24 PIN DIP				EA		10			

3.5

SUB./DATE: MATTEL/SYLVANIA MEETING 11/1/78
REVIEW OF OUTSTANDING TECHNICAL MATTERS

November 1, 1978

TO: Attendees:

Mattel
Dave Chandler
Cliff PerrySylvania (CMO)
Rusk Smith Tom Gouldy
Joe Hunt Bob Asplund
Howard Sprankle Granny Derr
Leo Buries Dave McGuire
Vance Larka John Bellotti

1. Mattel will change "Cassette" to "Cartridge".
2. Item 37 (Washer, Push-on) cannot define. Dave thinks it is a duplication. He will investigate and advise 11/2/78.
3. RF Shields - Mattel will not be able to define until after FCC testing. Logic Bd will have to be enclosed with connectors outside. FCC Consultant states that shields will have to be soldered to Board, Mattel feels they can be clipped on and are pushing for a clip arrangement. Shield will be metal. Dave will provide shield definition ASAP-preliminary shield definition by 11/15. Shields for 10 FCC units will be provided to G.I. by Mattel. Shields for 40 units will be provided by Mattel to CMO. There is a possibility that cartridges will have to be shielded. Mattel will assign part numbers for shields immediately.
4. Mattel will investigate if they will assign part number on paint and advise either a number or if we are to assign.
5. G.I. had advised the need for ferrite beads on the controller wires (1 per wire on each end). Dave does not think this is necessary and will check with G.I. on Thursday. CMO will be advised 11/2/78 p.m. by phone.
6. Cable assembly must have ferrite beads on each end. Mattel will breakdown parts list for antenna cable assy.
7. Controller will have flat circuitry with a special piece of bubbled mylar added (Domed Legend Overlay) which will be added to parts list.
8. Mattel will assign part numbers for ferrite beads on controller P/L item 46.
9. Parts list item 64 will be changed to radial.
10. Item 63 - 15/16" is the maximum height that can be allowed on any component on the power supply board.

11. Item 72 - Heatsink - we have Thermalloy part 6071B - should be 6072B?
12. Item 73 Rivet - We will only need 1 instead of 2.
(Regulator will dissipate 4 watts)
13. Drawing #39-159 was provided by Mattel (Pwr. Supply P.C. Layout) also the logic Bd. P.C. Layout #39-157 and cartridge board P.C. Layout Dwg. #39-158.
14. Dave will investigate with G.I. the need for 10 to 20 turn pots and advise 11/2/78.
15. Dave will define the TBD values for resistors (Items 88 thru 92) with GI and advise 11/2/78 those that can be pinned down at this time.
16. Item 96 - CMO can give either Axial leads or radial leads. CMO prefers axial.
Item 97 - CMO can give either Axial leads or radial leads. CMO prefers axial.
17. Item 93 and 95 was an assumption on CMO's part. Dave will check out with G.I. and advise 11/2/78.
18. CMO will use GI part numbers for Chips on master parts list.
19. Item 114 Crystal should be $\pm .001\%$ - CMO will assign part number.
20. Item 110 - Different conditions received with EMM quotes. CMO will provide info today to Dave to have clarified with GI on Thurs. Dave will advise CMO 11/2/78.
21. Item 115 - CMO will assign part number.
22. Item 116 - GI will spec.
23. Item 117 & 118 - CMO will assign part number.
24. Item 119 - Mattel part number 2609 - 9399 is applicable.
25. Item 120 - Ferrite Beads - Dave expects to resolve need at GI on Thurs. and will advise CMO 11/2/78.
26. Item 121 thru 125 - CMO will specify.
27. Master parts list, in a similar format as used in 11/1/78 meeting at CMO, to be issued by Mattel by 11/9/78 for use as a master to be used by Mattel, G.I. and Sylvania.

28. Chip testing

Current CMO pricing based on 0.65% AQL acceptance level at incoming test with full sets being returned to G.I. when failures are found. Dave will discuss with G.I. if the return of full sets will be required after first couple thousand units. Mattel will get commitment from G.I. on the process average they are willing to provide on matched sets and CMO will evaluate and advise impact to Mattel. Dave will get definition from G.I. as to what their 1% process average per component is and phone Vance Larka/Joe Hunt with info on 11/2/78. Dave will review with G.I. relative to any documentation that can be provided to CMO on chips so as to enable us to develop our test equipment.

29. Dave will discuss with G.I. and advise us their best date to provide CMO with both bare boards and completed assemblies to enable CMO to develop test equipment - CMO need is 12/1/78.
30. Bob Asnlund will join Dave Chandler and Cliff Perry at G.I. on 11/2/78 to obtain latest schematic and parts list on Logic Board. Sylvania will run a parallel program with G.I. in Logic Board circuit layout and manufacturing of initial Logic P.C. Boards.
31. Discussion was held relative to the problem of the time remaining between now and January for material procurement. Dave advised that the parts list which Mattel will release 11/9 will be the latest and should be used for start of procurement activities. Dave further advised that CMO should evaluate and if there are some long lead items that CMO cannot wait for the 11/9 P/L, CMO should advise Mattel and get advance authorization.
32. Cliff Perry will correlate P/L provided by Sylvania 11/1 and the documentation responsibility listing developed at Mattel during the Mattel/Sylvania/G.I. meeting of 9/27/78 and establish completion dates for outstanding items. Completion date for outstanding items - 11/9/78.
33. Trimmer cap. for frequency adjust must be adjustable from bottom. R. Asplund to confirm component used.
34. CMO assumes they will participate at G.I. in the testing of the 40 prototypes. Dave will discuss with G.I. and advise CMO 11/2/78.
35. Mattel will supply hand controller assembly sets and the plastic console housings to G.I. for 10 prototype units.

36. The system burn-in specification included in Item 27 of the minutes of the 9/27/78 meeting as set forth below was completed by recommending that one person per shift be assigned to be continually testing the systems from the first (2) weeks of production during the specified burn-in periods. This will provide more frequent data during the initial hours and less frequent during later hours. The systems are to be burned-in at room temperature. No T.V. is needed for each set during burn-in, but the cartridge must be plugged in during burn-in. Note that the assumption is that, during the rest of production, an 8-hour burn-in will be required.

Sylvania should be prepared to activate such a burn-in program.

250 unit pilot run	-	Burn-in 168 hrs.
50 per day 1st week	-	250 units - Burn-in 168 hrs.
75 per day 2nd week	-	375 units - Burn-in 48 hrs.
125 per day 3rd week	-	625 units - Burn-in 8 hrs.
All follow-on production	-	Burn-in 8 hrs.

NOTE: Where item number is used - reference is to item number on attached parts list.

JOHN R. ROBERTSON

2609-9993 STANDARD PACK (1978)

ITEM	REV	PART NUMBER	DWG. SIZE	NUMBER REQUIRED FOR NEXT ASSEMBLY								UNIT OF MEAS.	PART DESCRIPTION	SUGGESTED SOURCE	
				1	2	3	4	5	6	7	8				
1		2609-0930	B	1									Ea.	Master Carton	
2		0405-0790	A	A/R									A/R	Tape - 3" Reinforced	
3		2609-9992			6								Ea.	Toy in Individual Labelled Carton	
4		2609-9219				1							Ea.	Individual Carton - Labelled	
5		2609-0910	B				1						Ea.	Individual Carton	
6		2609-0970	A					1					Ea.	Label	
7		0405-9950	A			A/R							A/R	Tape - 2" Clear	
8		2609-0810	D			2							Ea.	End Cap - Styrofoam Bead	
9		0405-0290	A			A/R							A/R	Tape - 1" Clear	
10		0001-9210	A			1							Ea.	Polyethylene Sleeve (11½" x 24")	
11		2609-0920				1							Ea.	Instruction Sheet	
12		2610-9991				1							Ea.	Football <i>Cassette</i>	
13		2609-9991				1							Ea.	Video Game	
14		2609-9109					1						Ea.	Console Assembly	
15		2609-2109						1					Ea.	Console Base	
16		2609-2149						1					Ea.	Tray	
17		0405-0802						6					Ea.	Screw, 8-18x1"	Shakeproof Hi-Lo
18		0405-0812						6					Ea.	Screw, 8-18x½"	Shakeproof Hi-Lo
19		2609-9549						1					Ea.	Transformer Assembly	Mi dwest

ITEM	REV	PART NUMBER	DWG. SIZE	NUMBER REQUIRED FOR NEXT ASSEMBLY								UNIT OF MEAS.	PART DESCRIPTION	SUGGESTED SOURCE	
				1	2	3	4	5	6	7	8				
20		-							1				Ea.	Connector, 5 Pin - For Transformer	Amp #640428-5 Molex KK .156" Series
21		0405-0822							2				Ea.	Screw, 6-19x $\frac{1}{2}$ "	Shakeproof Hi-Lo
22		-							1				Ea.	Shield, R. F. Upper	
23		-							1				Ea.	Shield, R. F. Lower	
24		2609-0230							1				Ea.	Insulator, 3" x 4" Fish Paper	Wilmington Fiber, Synthane-Taylor
25		2609-9489							4				Ea.	Adhesive Foot, .14" Thk. x .5" Dia., Polyurethane	3M #SJ-5012
26		2609-9119							1				Ea.	Console Cover - Labelled	
27		2609-0320							1				Ea.	Label - Plain	
28		2609-0330							1				Ea.	Label - Controls	
29		2609-6119							1				Ea.	Console Cover - Painted	
30		-							A/R				A/R	Patnt	
31		2609-2119							1				Ea.	Console Cover	
32		0405-0832							6				Ea.	Screw, 8-18x3/4"	Shakeproof Hi-Lo
33		2609-2129							1				Ea.	Button - Reset	
34		2609-4269							1				Ea.	Spring - for Reset Button	
35		0405-0852							1				Ea.	Pushnut Fastener	Palmut #PD 156007
36		2609-2139							1				Ea.	Glamour Cap	
37		-							1				Ea.	Washer, Push-on	

EXHIBIT C

2609-9993 STANDARD PACK (1978) (Continued)

ITEM	PART NUMBER	DWG. SIZE	NUMBER REQUIRED FOR NEXT ASSEMBLY								UNIT OF MEAS.	PART DESCRIPTION	SUGGESTED SOURCE	
			1	2	3	4	5	6	7	8				
38	2609-9599							1				Ea.	Antenna Cable Assembly <i>2 pins</i>	Astec; Columbia Electronic Cables
39	2609-9609							1				Ea.	Antenna Switch Assembly <i>2 pins</i>	Astec
40	2611-0340							1				Ea.	Label - Serial Number	
41	2609-9059							2				Ea.	Hand Controller Assembly	
42	2609-9579							1				Ea.	Controller Cable Assembly w/Connectors	
43	2609-9569							1				Ea.	Cable, 9 Wire, Coiled	Victor
44	2609-9469							1				Ea.	Connector - Controller, 9 Pin	Circuit Assembly Corp.
45	2609-9479							1				Ea.	Connector - Console, 10 Pin, Card Edge	Molex
46	-							9				Ea.	Ferrite Bead; .20" ID, .38" OD, .19" L	Fair-Rite #263000801
47	2609-2059	E						1				Ea.	Housing, Lower	
48	2609-9589							1				Ea.	Circuit Matrix	Chomerics
49	2609-2099	C						2				Ea.	<i>FOR</i> Push Buttons <i>DOMED LEGEND</i>	
50	2609-9089							1				Ea.	Disc - Control w/Inlay	
51	2609-2089	B						1				Ea.	Disc - Control	
52	2609-0310							1				Ea.	Inlay	
53	2609-9069							1				Ea.	Housing - Upper Subassembly	
54	2609-2069	E						1				Ea.	Housing - Upper	
55	2609-2079	C						1				Ea.	Frame	

EXHIBIT C

2609-9993 (Continued)

ITEM	REV	PART NUMBER	DWG. SIZE	NUMBER REQUIRED FOR NEXT ASSEMBLY								UNIT OF MEAS.	PART DESCRIPTION	SUGGESTED SOURCE	
				1	2	3	4	5	6	7	8				
56		0405-0842								4			Ea.	Screw, 5-20 x 7/16"	Shakeproof Hi-Lo
57		0405-4279								1			Ea.	Compression Spring	
58		2609-9539								1			Ea.	Power Supply Board Assembly Per G.I. Parts List #39-147 Rev. B	
59										1			Ea.	IC1 - 7805C Positive Voltage Regulator, 5V + 5%, TO-220 Package	Signetics, TI, National, Fairchild, Motorola, NEC
60										1			Ea.	IC2 - 7812C Positive Voltage Regulator, 12V + 5%, TO-220 Package	Signetics, TI, National, Fairchild, Motorola, NEC
61										8			Ea.	D1-D8: IN4001, Rectifier, 1 Amp, 50V	GI, ITT
62										1			Ea.	D9 - IN746A, Zener, 3.3V, 5%, 500 mW	NPC, Motorola, Siemens, Fairchild, NEC
63										1			Ea.	C1 - Aluminum Cap., 10,000 uF, -10+100%, 16V, Axial	United Chemi-Con #16TAL10000, Nichicon, Elna, Illinois Cap.
64										1			Ea.	C2 - Aluminum Cap., 100 uF, -10+100%, 25V, Axial	United Chemi-Con #25TAL100, Elna, Nichicon, Illinois Cap.
65										3			Ea.	C4,5,6 - Ceramic Cap., 0.1 uF, 20%, 15V, Z5U, Radial	Centralab Type 2DDU, Erie Transcap, Dilectron Type RT, Murata, KCK
66										1			Ea.	R1 - Carbon Film, 220 Ohm, 5%, 1/2W	Airco, R-0hm, ICC
67										1			Ea.	C3 - Aluminum Cap., 1000 uF, -10+100%, 25V, Axial	United Chemi-con #35TAL1000, Elna, Nichicon #35TAL1000, Illinois Cap.
68										1			Ea.	Power Switch, 3PST Slide	UID #SW432-SD-L0-S-B1-JK
69										9			Ft.	Wire, 22 AWG, 7/30 Stranded	American Electric Cable, Teledyne Thermatics

ITEM	REV	PART NUMBER	DWG. SIZE	NUMBER REQUIRED FOR NEXT ASSEMBLY								UNIT OF MEAS.	PART DESCRIPTION	SUGGESTED SOURCE	
				1	2	3	4	5	6	7	8				
70		-								1			Ea.	Connector, P/C Header, 5 Pin, to Transformer	Amp #640383-5, Molex KK.156" Series
71		-								1			Ea.	Connector, P/C Header, 6 Pin to Logic Board	Amp #640383-6 Molex KK.156" Series
72		-								1			Ea.	Heatsink for T0-220 Package	Thermalloy #6071B
73		-								2			Ea.	Rivet	Keystone
74		-								1			Ea.	P/C Board, NEMA Grade CEM-1, .062" Thk. Single-sided, 12.2 Sq. In., Bare Copper Circuit	
75		2609-9519								1			Ea.	Logic Board Assembly per G.I. Parts List #39-147 Rev. B	
76		-								2			Ea.	R1, 5 - Resistor, Carbon Film, 1K Ohm, 5%, 1/4W	Airco, R-0hm, ICC
77		-								1			Ea.	R2 - Res., Carbon Film, 47 Ohm, 5%, 1/4W	
78		-								1			Ea.	R4 - Res., Carbon Film, 300 Ohm, 5%, 1/4W	
79		-								2			Ea.	R7,8 - Res., Carbon Film, 3.3K Ohm, 5%, 1/4W	
80		-								1			Ea.	R9 - Res., Carbon Film, 560 Ohm, 5%, 1/4W	
81		-								1			Ea.	R10 - Res., Carbon Film, 10K Ohm, 5%, 1/4W	
82		-								1			Ea.	R11 - Res., Carbon Film, 100 Ohm, 5%, 1/4W	
83		-								3			Ea.	R13,14,23 - Res., Carbon Film, 10 Ohm, 5%, 1/4W	Airco, R-0hm, ICC

ITEM	REV	PART NUMBER	DWG. SIZE	NUMBER REQUIRED FOR NEXT ASSEMBLY								UNIT OF MEAS.	PART DESCRIPTION	SUGGESTED SOURCE	
				1	2	3	4	5	6	7	8				
84	-	-								1			Ea.	R16 - Res., Carbon Film, 470 Ohm, 5%, 1/4W	Airco, R-0hm, ICC
85	-	-								1			Ea.	R17 - Res., Carbon Film, 2.2K Ohm, 5%, 1/4W	
86	-	-								1			Ea.	R18 - Res., Carbon Film, 200K Ohm, 5%, 1/4W	
87	-	-								1			Ea.	R30 - Res., Carbon Film, 150 Ohm, 5%, 1/4W	
88	-	-								3			Ea.	R3,6,15 - Res., Carbon Film, TBD, 5%, 1/4W	
89	-	-								3			Ea.	R19,20,21 - Res., Carbon Film, TBD, 5%, 1/4W	
90	-	-								3			Ea.	R22,26,27 - Res., Carbon Film, TBD, 5%, 1/4W	Airco, R-0hm, ICC
91	-	-								3			Ea.	R24,25,28 - Potentiometer, Carbon, TBD, 20%, 1/4W @ 550C, 270° Rotation, P/C Mount, .65" Dia., Open Construction	Piher PT 15YD, Stackpole, CTS
92	-	-								1			Ea.	R29 - Potentiometer, Carbon, TBD, 20%, 1/4W @55 C, 270° Rotation, P/C Mount, .65" Dia., Open Construction	Piher PT 15YD, Stackpole, CTS
93	-	-								1			Ea.	C1 - Ceramic Cap., 20pF, 5%, 15V, NP0, Radial	Centralab Type 2DDT, Erie Type 801, Dilectron, Murata, KCK
94	-	-								20			Ea.	C4-22,24 - Ceramic Cap., 0.1uF, 20%, 15V, Z5U, Radial	Centralab Type 2DDU, Erie Transcap, Dilectron Type RT, Murata, KCK

EXHIBIT C

2609-9993 (Continued)

ITEM	REV	PART NUMBER	DWG. SIZE	NUMBER REQUIRED FOR NEXT ASSEMBLY								UNIT OF MEAS.	PART DESCRIPTION	SUGGESTED SOURCE	
				1	2	3	4	5	6	7	8				
95		-								1			Ea.	C25 - Ceramic Cap., 100pF, 5%, 15V, NP0, Radial	Centralab Type 2DDT, Erie Type 841, Dilectron, Murata KCK
96		-								2			Ea.	C3,26 - Aluminum Cap., 1uf, -10+100%, 15V, Axial	United Chemi-con 16TAL100, Illinois Capacitor, Elna, Nichicon
97		-								3			Ea.	C27,28,30 - Solid Tantalum Cap., 10uF, 20%, 35V, Radial	Sprague 199D, Kemet T392D, Elna, ITT, NEC
98		-								1			Ea.	C31 - Ceramic Cap., .01uF, 20%, 15V, Z5U, Radial	Centralab Type 2DDU, Erie Transcap, Dilectron Type RT, Murata, KCK
99		-								1			Ea.	D1 - Rectifier, IN4001, 1 Amp, 50V	GI, ITT
100		-								2			Ea.	Q1,2 - 2N3906, PNP Small Transistor	Fairchild, National, ITT, NPC, NEC
101		-								1			Ea.	Q3 - 2N3904, NPN Small Signal Trans.	Fairchild, National, ITT, NPC, NEC
102		-								1			Ea.	IC1 - CP1610, uP	GI
103		-								1			Ea.	IC2 - RA-3-9600, RAM	GI
104		-								1			Ea.	IC3 - R0-3-9504, 2KX10 ROM	GI
105		-								1			Ea.	IC4 - AY-3-9600, STIC	GI
106		-								1			Ea.	IC5 - R0-3-9503, 16K ROM	GI
107		-								1			Ea.	IC6 - AY-3-8910, PSG	GI
108		-								1			Ea.	IC9 - R0-3-9502, 2KX10 ROM	GI
109		-								1			Ea.	IC10 - AY-3-8915, Color	GI

new G.F. Part numbers

ITEM	REV	PART NUMBER	DWG. SIZE	NUMBER REQUIRED FOR NEXT ASSEMBLY								UNIT OF MEAS.	PART DESCRIPTION	SUGGESTED SOURCE	
				1	2	3	4	5	6	7	8				
110		-								3			Ea.	IC7, 8, 12 - 256x8 RAM	EMM-Semi 3539 UCP
111		-								1			Ea.	IC11 - 7406, Hex Inverter	Fairchild, National, TI, Signetics, NEC
112		-								1			Ea.	IC13 - 74LS08, Quad and Gate	Fairchild, National, TI, Signetics, Motorola
113		-								2			Ea.	IC14,15 - 74LS126, Quad Buffer	Fairchild, National, TI, Signetics, Motorola
114		-								1			Ea.	XTL - Crystal, 3.579545 MHZ, + ⁰⁰¹ .01%	Erie, Electro-Dynamics Reeves-Hoffman, Q-Matic
115		-								1			Ea.	C2 - Trimmer Cap., 5.1-50PF, Ceramic, .35" Dia., P/C Mount	Matsushita #FCY-1ZW50X321H Sprague-Goodman #6KD50000
116		-	GI							1			Ea.	RFX - Modulator	Astec #UM1285
117		-								1			Ea.	S1 - SPST Switch	CTS Dwg. C1690A
118		-								1			Ea.	S2 - SPDT Slide Switch, P/C Mount	UID #SL-012-SD-T0-P-B1-EK-CE
119		-	2609-4399							1			Ea.	Connector, P/C Card Edge, 44 Pin	Method
120		-								6			Ea.	Ferrite Bead, .20" ID, .38" OD, .19" L	Fair-Rite #263000801
121		-								6			Ea.	IC Socket, 40 Pin DIP	T.I. #C8540-01, Augat, Cambion
122		-								1			Ea.	IC Socket, 18 Pin DIP	T.I. #C8518-01, Augat, Cambion
123		-								1			Ea.	IC Socket, 28 Pin DIP	T.I. #C8528-01, Augat, Cambion
124		-								1			Ea.	Connector, 6 Pin - To P/S Board	Amp #640428-6 Molex KK.156" Series
125		-								.5			Ft.	Wire, 22 AWG, 7/30 Stranded	American Electric Cable, Teledyne Thermatics

ITEM	REV	PART NUMBER	DWG. SIZE	NUMBER REQUIRED FOR NEXT ASSEMBLY								UNIT OF MEAS.	PART DESCRIPTION	SUGGESTED SOURCE	
				1	2	3	4	5	6	7	8				
126		-								1			Ea.	P/C Board, NEMA Grade CEM-1, .062" Thk., Double-sided, PTH, 48.8 Sq. In. Solder Mask One Side, Solder Plated Copper Circuit	

BASIC SLIDE SWITCHES

	TYPE NUMBER AND CONTACT RATING	DESCRIPTION	SCHEMATIC	RATINGS* ALL U.L. LISTED		HOUSING DIMENSIONS						
				SINGLE POLE — C.S.A. APPROVED AC AMPS @ 125 V.		FIG. NO.	WIDTH DIM. "A"	MOUNTING CENTERS DIM. "B"	OVERALL LENGTH DIM. "C"	BODY LENGTH DIM. "D"	BUTTON WINDOW DIM. "E"	
SINGLE POLE	SW-311-M	SP-ST Normally Open Momentary		3.0 not CSA Listed		17	.546	1.125	1.380	.875	.285	
	SW-411* SW-511* SW-7511* SW-411-L*	SW-611 SW-1011* SW-611-L	SP-ST	4.0 5.0 7.5 4.0	6.0 10.1 6.0	7 7 1	.546	1.125 1.625	1.380 1.875	.875	.468	
	SW-411-SR* SW-411-SR-L*	SW-611-SR SW-611-SR-L	SP-ST Spring Ret. Norm Open	4.0 4.0	6.0 6.0	14 14	.546	1.125 1.625	1.380 1.875	.875	.468	
	SW-412 SW-512* SW-7512* STV-112 ST-612	SW-612 SW-1012 STV-212 ST-612	SP-DT	4.0 5.0 7.5 6.0	6.0 10.1 TV-1 TV-2 3-250 vac	7 7 1 10	.546 .546 .546 .556 .546	1.125	1.380	.875 .875 .875 .900*** .875	.468	
	SW-412-SR SW-412-SR-L	SW-612-SR SW-612-SR-L	SP-DT Spring Ret.	4.0 4.0	6.0 6.0	14 14	.546	1.125 1.625	1.380 1.880	.875	.468	
	SW-412-SO-P	SW-612-SO-P	SP-DT Side operated	4.0	6.0	5	.546	1.180	1.260	.875	.540	
	SW-412-PI-P*	SW-612-PI-P	SP-DT Plug in mounting	4.0	6.0	6	.546	1.180	1.260	.875	.510	
	SW-412-TT-P*	SW-612-TT-P	SP-DT Twist Tab	4.0	6.0	8	.546	1.315	1.365	.875	.468	
	SW-413* SW-413-L*	SW-613 SW-613-L	SP-TT	4.0 4.0	6.0 6.0	1	.546	1.406 1.625	1.656 1.880	1.125	.723	
	DOUBLE POLE	SW-422* SW-422-L* SW-422-SR* SW-422-SR-L*	SW-622 SW-622-L SW-622-SR SW-622-SR-L	DP-DT DP-DT Spring Return	4.0 4.0 4.0 4.0	6.0 6.0 6.0 6.0	2 3	.546 .734	1.125 1.625 1.125 1.625	1.380 1.880 1.380 1.880	.875	.468
SW-422-SO-P SW-422-PI-P*		SW-622-SO-P SW-622-PI-P	DP-DT DP-DT Plug in mounting	4.0 4.0	6.0 6.0	5 6	.546 .546	1.180 1.180	1.260 1.260	.875 .875	.540 .510	
SW-422-TT SW-422-PP*		SW-622-TT SW-622-PP	DP-DT DP-DT Push-Pull	4.0 4.0	6.0 6.0	8 9	.546 .546	1.315 —	1.365 .890	.875 .890	.468 —	
SW-423-TT* SW-423* SW-423-L* SW-423-PP-P* SW-323-SO		— SW-623, SW-823 SW-623-L SW-623-PP	DP-TT	4.0 4.0 4.0 4.0 3.0	6.0 6.0 8.0 6.0 6.0	15 2 2 9 16	.546 .546 .546 .546 .546	1.340 1.406 1.625 — 1.406	1.365 1.660 1.880 1.125 1.656	1.125 1.125 1.125 1.125 1.125	.723 .723 .723 — .785	
** SW-423-SRO-M ** SW-423-SRO ** SW-423-SRO-L		SW-623-SRO-M SW-623-SRO SW-623-SRO-L	DP-TT Spring Return from one end	4.0 4.0 4.0	6.0 6.0 6.0	3	.734	1.375 1.406 1.625	1.630 1.660 1.880	1.125	.723	
** SW-423-SRC-M ** SW-423-SRC ** SW-423-SRC-L		SW-623-SRC-M SW-623-SRC SW-623-SRC-L	DP-TT Spring Return from both ends	4.0 4.0 4.0	6.0 6.0 6.0	4	.937	1.375 1.406 1.625	1.630 1.660 1.880	1.125	.723	
TRIPLE POLE		SW-432 SW-432-L SW-432-SR SW-432-SR-L	SW-632 SW-632-L SW-632-SR SW-632-SR-L	TP-DT TP-DT Spring Return	4.0 4.0 4.0 4.0	6.0 6.0 6.0 6.0	12 13	.734 .937	1.125 1.625 1.125 1.625	1.380 1.880 1.380 1.880	.875	.468
		SW-433-M SW-433 SW-433-L	SW-633-M SW-633 SW-633-L	TP-TT	4.0 4.0 4.0	6.0 6.0 6.0	12	.734	1.375 1.406 1.625	1.630 1.660 1.880	1.125	.723
		FOUR POLE	SW-442 SW-442-L	SW-642 SW-642-L	4P-DT	4.0 4.0	6.0 6.0	13	.937	1.125 1.625	1.380 1.880	.875
SW-443-M SW-443 SW-443-L			SW-643-M SW-643 SW-643-L	4P-TT	4.0 4.0 4.0	6.0 6.0 6.0	13	.937	1.375 1.406 1.625	1.630 1.660 1.880	1.125	.723

*All 4 AMP switches are U.L. listed at 125 VAC, 1.5 AMP at 250 VAC and 0.5 AMPS at 125 VDC. All 6 AMP switches are U.L. listed at 125 VAC and 0.5 AMPS at 125 VDC. Standard DP switches with solder guard are CSA listed. For specific ratings, please contact factory.
 **19/32" nylon handle only.

• 3/16" Terminal Spacing *** 940 Over Tabs on Terminal Board

FIGURE 8.
DOUBLE POLE, DOUBLE THROW
- TWIST TAB

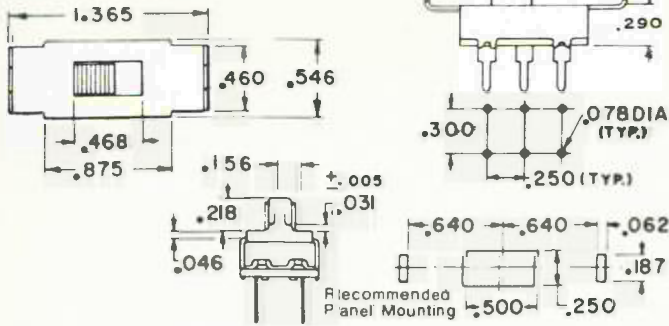
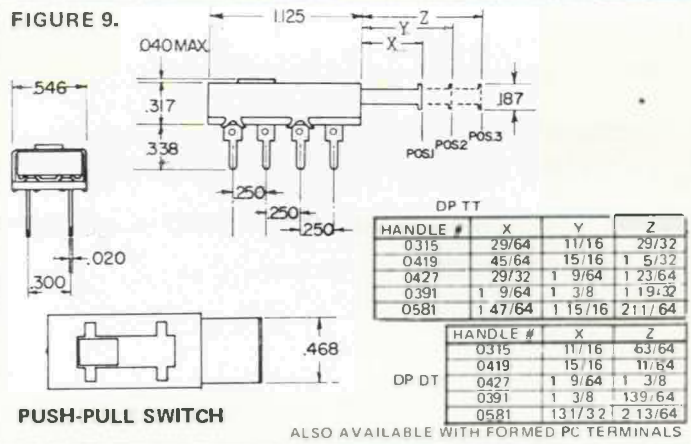

FIGURE 9.



PUSH-PULL SWITCH

FIGURE 10

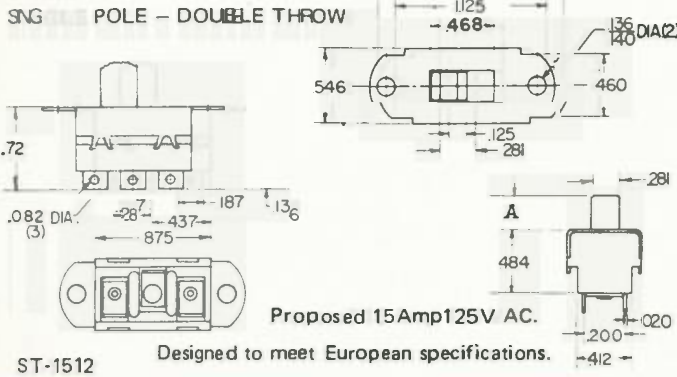
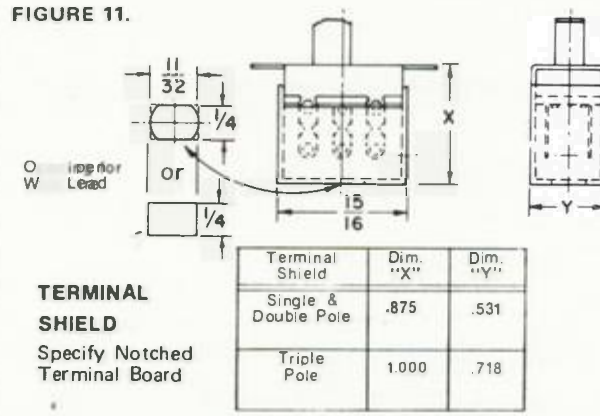

FIGURE 11.



TERMINAL SHIELD

Specify Notched Terminal Board

TRIPLE POLE, DOUBLE & TRIPLE THROW

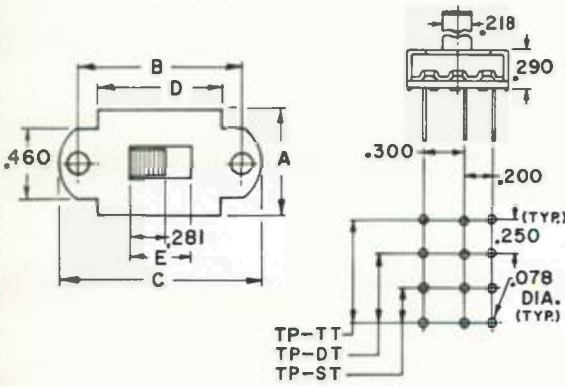

FIGURE 12.

FOUR POLE DOUBLE & TRIPLE THROW TRIPLE POLE SPRING RETURN

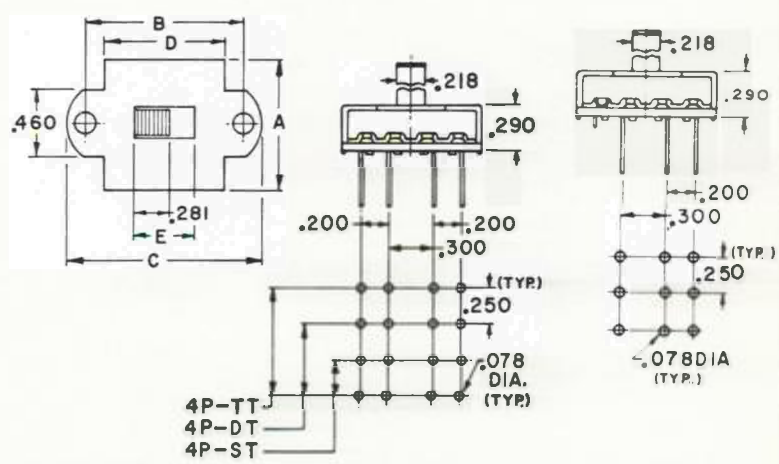

FIGURE 13.

TERMINALS (.020 Thick)

S-Solder Lug (Standard)

F - Faston

H - Half Terminal (Short Solder Terminal)

P-Printed Circuit

A -Printed Circuit

W-Wire Wrap

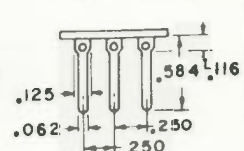
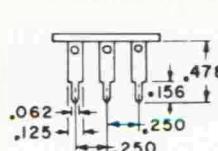
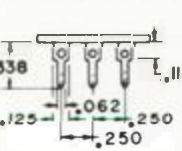
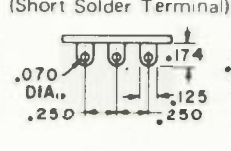
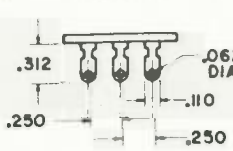
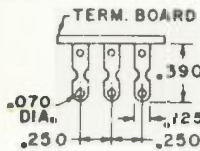

GLAMOUR CAPS

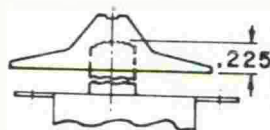
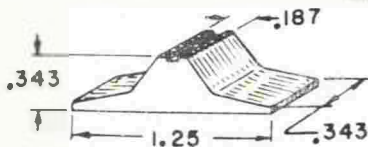

BUTTONS

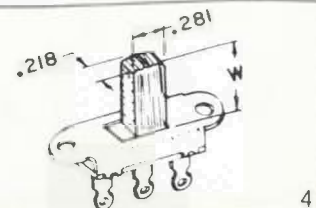

cricket rest switch - plastic button not long enough

questionnaire circuit switch

channel 3-4 switch - doesn't match holes

shielding - $8\frac{1}{2}$ long bd.

P5 bd. - more area for π filter
cable dressing 1 sq. in.

plastic

Switches
connectors

flares of ports by modulator

end mount capacitors
trim pot
trim cap

* memory map — make official change

astec — get Energy to GI

↓ feedthrough ~~lead~~ doesn't reach board