

SUB./DATE: MATTEL/SYLVANIA MEETING 11/1/78  
REVIEW OF OUTSTANDING TECHNICAL MATTERS

November 1, 1978

TO: Attendees:

Mattel  
Dave Chandler  
Cliff PerrySylvania (CMO)  
Rusk Smith      Tom Gouldy  
Joe Hunt        Bob Asplund  
Howard Sprankle    Granny Derr  
Leo Buries        Dave McGuire  
Vance Larka        John Bellotti

1. Mattel will change "Cassette" to "Cartridge".
2. Item 37 (Washer, Push-on) cannot define. Dave thinks it is a duplication. He will investigate and advise 11/2/78.
3. RF Shields - Mattel will not be able to define until after FCC testing. Logic Bd will have to be enclosed with connectors outside. FCC Consultant states that shields will have to be soldered to Board, Mattel feels they can be clipped on and are pushing for a clip arrangement. Shield will be metal. Dave will provide shield definition ASAP-preliminary shield definition by 11/15. Shields for 10 FCC units will be provided to G.I. by Mattel. Shields for 40 units will be provided by Mattel to CMO. There is a possibility that cartridges will have to be shielded. Mattel will assign part numbers for shields immediately.
4. Mattel will investigate if they will assign part number on paint and advise either a number or if we are to assign.
5. G.I. had advised the need for ferrite beads on the controller wires (1 per wire on each end). Dave does not think this is necessary and will check with G.I. on Thursday. CMO will be advised 11/2/78 p.m. by phone.
6. Cable assembly must have ferrite beads on each end. Mattel will breakdown parts list for antenna cable assy.
7. Controller will have flat circuitry with a special piece of bubbled mylar added (Domed Legend Overlay) which will be added to parts list.
8. Mattel will assign part numbers for ferrite beads on controller P/L item 46.
9. Parts list item 64 will be changed to radial.
10. Item 63 - 15/16" is the maximum height that can be allowed on any component on the power supply board.

11. Item 72 - Heatsink - we have Thermalloy part 6071B - should be 6072B?
12. Item 73 Rivet - We will only need 1 instead of 2.  
(Regulator will dissipate 4 watts)
13. Drawing #39-159 was provided by Mattel (Pwr. Supply P.C. Layout) also the logic Bd. P.C. Layout #39-157 and cartridge board P.C. Layout Dwg. #39-158.
14. Dave will investigate with G.I. the need for 10 to 20 turn pots and advise 11/2/78.
15. Dave will define the TBD values for resistors (Items 88 thru 92) with GI and advise 11/2/78 those that can be pinned down at this time.
16. Item 96 - CMO can give either Axial leads or radial leads. CMO prefers axial.  
Item 97 - CMO can give either Axial leads or radial leads. CMO prefers axial.
17. Item 93 and 95 was an assumption on CMO's part. Dave will check out with G.I. and advise 11/2/78.
18. CMO will use GI part numbers for Chips on master parts list.
19. Item 114 Crystal should be  $\pm .001\%$ - CMO will assign part number.
20. Item 110 - Different conditions received with EMM quotes. CMO will provide info today to Dave to have clarified with GI on Thurs. Dave will advise CMO 11/2/78.
21. Item 115 - CMO will assign part number.
22. Item 116 - GI will spec.
23. Item 117 & 118 - CMO will assign part number.
24. Item 119 - Mattel part number 2609 - 9399 is applicable.
25. Item 120 - Ferrite Beads - Dave expects to resolve need at GI on Thurs. and will advise CMO 11/2/78.
26. Item 121 thru 125 - CMO will specify.
27. Master parts list, in a similar format as used in 11/1/78 meeting at CMO, to be issued by Mattel by 11/9/78 for use as a master to be used by Mattel, G.I. and Sylvania.

28. Chip testing

Current CMO pricing based on 0.65% AQL acceptance level at incoming test with full sets being returned to G.I. when failures are found. Dave will discuss with G.I. if the return of full sets will be required after first couple thousand units.

Mattel will get commitment from G.I. on the process average they are willing to provide on matched sets and CMO will evaluate and advise impact to Mattel.

Dave will get definition from G.I. as to what their 1% process average per component is and phone Vance Larka/Joe Hunt with info on 11/2/78.

Dave will review with G.I. relative to any documentation that can be provided to CMO on chips so as to enable us to develop our test equipment.

29. Dave will discuss with G.I. and advise us their best date to provide CMO with both bare boards and completed assemblies to enable CMO to develop test equipment - CMO need is 12/1/78.
30. Bob Asplund will join Dave Chandler and Cliff Perry at G.I. on 11/2/78 to obtain latest schematic and parts list on Logic Board. Sylvania will run a parallel program with G.I. in Logic Board circuit layout and manufacturing of initial Logic P.C. Boards.
31. Discussion was held relative to the problem of the time remaining between now and January for material procurement. Dave advised that the parts list which Mattel will release 11/9 will be the latest and should be used for start of procurement activities. Dave further advised that CMO should evaluate and if there are some long lead items that CMO cannot wait for the 11/9 P/L, CMO should advise Mattel and get advance authorization.
32. Cliff Perry will correlate P/L provided by Sylvania 11/1 and the documentation responsibility listing developed at Mattel during the Mattel/Sylvania/G.I. meeting of 9/27/78 and establish completion dates for outstanding items. Completion date for outstanding items - 11/9/78.
33. Trimmer cap. for frequency adjust must be adjustable from bottom. R. Asplund to confirm component used.
34. CMO assumes they will participate at G.I. in the testing of the 40 prototypes. Dave will discuss with G.I. and advise CMO 11/2/78.
35. Mattel will supply hand controller assembly sets and the plastic console housings to G.I. for 10 prototype units.



36. The system burn-in specification included in Item 27 of the minutes of the 9/27/78 meeting as set forth below was completed by recommending that one person per shift be assigned to be continually testing the systems from the first (2) weeks of production during the specified burn-in periods. This will provide more frequent data during the initial hours and less frequent during later hours. The systems are to be burned-in at room temperature. No T.V. is needed for each set during burn-in, but the cartridge must be plugged in during burn-in. Note that the assumption is that, during the rest of production, an 8-hour burn-in will be required.

Sylvania should be prepared to activate such a burn-in program.

250 unit pilot run	-	Burn-in 168 hrs.
50 per day 1st week	-	250 units - Burn-in 168 hrs.
75 per day 2nd week	-	375 units - Burn-in 48 hrs.
125 per day 3rd week	-	625 units - Burn-in 8 hrs.
All follow-on production	-	Burn-in 8 hrs.

NOTE: Where item number is used - reference is to item number on attached parts list.

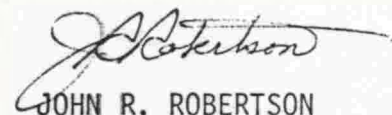

JOHN R. ROBERTSON



2609-9993 STANDARD PACK (1978)

REV	PART NUMBER	DWG. SIZE	NUMBER REQUIRED FOR NEXT ASSEMBLY								UNIT OF MEAS.	PART DESCRIPTION	SUGGESTED SOURCE	
			1	2	3	4	5	6	7	8				
	2609-0930	B	1									Ea.	Master Carton	
	0405-0790	A	A/R									A/R	Tape - 3" Reinforced	
	2609-9992			6								Ea.	Toy in Individual Labelled Carton	
	2609-9219				1							Ea.	Individual Carton - Labelled	
	2609-0910	B				1						Ea.	Individual Carton	
	2609-0970	A				1						Ea.	Label	
	0405-9950	A			A/R							A/R	Tape - 2" Clear	
	2609-0810	D			2							Ea.	End Cap - Styrofoam Bead	
	0405-0290	A			A/R							A/R	Tape - 1" Clear	
	0001-9210	A			1							Ea.	Polyethylene Sleeve (11½" x 24")	
	2609-0920				1							Ea.	Instruction Sheet	
	2610-9991				1							Ea.	Football Cassette	
	2609-9991				1							Ea.	Video Game	
	2609-9109					1						Ea.	Console Assembly	
	2609-2109							1				Ea.	Console Base	
	2609-2149							1				Ea.	Tray	
	0405-0802							6				Ea.	Screw, 8-18x1"	Shakeproof Hi-Lo
	0405-0812							6				Ea.	Screw, 8-18x½"	Shakeproof Hi-Lo
	2609-9549							1				Ea.	Transformer Assembly	Midwest

EXHIBIT C

2609-9993 (Continued)

ITEM	REV	PART NUMBER	DWG. SIZE	NUMBER REQUIRED FOR NEXT ASSEMBLY								UNIT OF MEAS.	PART DESCRIPTION	SUGGESTED SOURCE	
				1	2	3	4	5	6	7	8				
20		-					1						Ea.	Connector, 5 Pin - For Transformer	Amp #640428-5 Molex KK .156" Series
21		0405-0822					2						Ea.	Screw, 6-19x $\frac{1}{2}$ "	Shakeproof Hi-Lo
22		-					1						Ea.	Shield, R. F. Upper	
23		-					1						Ea.	Shield, R. F. Lower	
24		2609-0230					1						Ea.	Insulator, 3" x 4" Fish Paper	Wilmington Fiber, Synthane-Taylor
25		2609-9489					4						Ea.	Adhesive Foot, .14" Thk. x .5" Dia., Polyurethane	3M #SJ-5012
26		2609-9119					1						Ea.	Console Cover - Labelled	
27		2609-0320					1						Ea.	Label - Plain	
28		2609-0330					1						Ea.	Label - Controls	
29		2609-6119					1						Ea.	Console Cover - Painted	
30		-								A/R			A/R	Paint	
31		2609-2119								1			Ea.	Console Cover	
32		0405-0832					6						Ea.	Screw, 8-18x3/4"	Shakeproof Hi-Lo
33		2609-2129					1						Ea.	Button - Reset	
34		2609-4269					1						Ea.	Spring - for Reset Button	
35		0405-0852					1						Ea.	Pushnut Fastener	Palmut #PD 156007
36		2609-2139					1						Ea.	Glamour Cap	
37		-					1						Ea.	Washer, Push-on	

EXHIBIT C

2609-9993 STANDARD PACK (1978) (Continued)

ITEM	REV	PART NUMBER	DWG. SIZE	NUMBER REQUIRED FOR NEXT ASSEMBLY								UNIT OF MEAS.	PART DESCRIPTION	SUGGESTED SOURCE	
				1	2	3	4	5	6	7	8				
38		2609-9599						1					Ea.	Antenna Cable Assembly	Astec; Columbia Electronic Cables
39		2609-9609						1					Ea.	Antenna Switch Assembly	Astec
40		2611-0340						1					Ea.	Label - Serial Number	
41		2609-9059						2					Ea.	Hand Controller Assembly	
42		2609-9579						1					Ea.	Controller Cable Assembly w/Connectors	
43		2609-9569						1					Ea.	Cable, 9 Wire, Coiled	Victor
44		2609-9469						1					Ea.	Connector - Controller, 9 Pin	Circuit Assembly Corp.
45		2609-9479						1					Ea.	Connector - Console, 10 Pin, Card Edge	Molex
46		-						9					Ea.	Ferrite Bead; .20" ID, .38" OD, .19" L	Fair-Rite #263000801
47		2609-2059	E					1					Ea.	Housing, Lower	
48		2609-9589						1					Ea.	Circuit Matrix	Chomerics
49		2609-2099	C					2					Ea.	Push Buttons	
50		2609-9089						1					Ea.	Disc - Control w/Inlay	
51		2609-2089	B					1					Ea.	Disc - Control	
52		2609-0310						1					Ea.	Inlay	
53		2609-9069						1					Ea.	Housing - Upper Subassembly	
54		2609-2069	E					1					Ea.	Housing - Upper	
55		2609-2079	C					1					Ea.	Frame	



EXHIBIT C

2609-9993 (Continued)

REV	PART NUMBER	DWG. SIZE	NUMBER REQUIRED FOR NEXT ASSEMBLY								UNIT OF MEAS.	PART DESCRIPTION	SUGGESTED SOURCE
			1	2	3	4	5	6	7	8			
6	0405-0842							4			Ea.	Screw, 5-20 x 7/16"	Shakeproof Hi-Lo
7	0405-4279							1			Ea.	Compression Spring	
8	2609-9539								1		Ea.	Power Supply Board Assembly Per G.I. Parts List #39-147 Rev. B	
9	-								1		Ea.	IC1 - 7805C Positive Voltage Regulator, 5V + 5%, TO-220 Package	Signetics, TI, National, Fairchild, Motorola, NEC
0	-								1		Ea.	IC2 - 7812C Positive Voltage Regulator, 12V + 5%, TO-220 Package	Signetics, TI, National, Fairchild, Motorola, NEC
1	-								8		Ea.	D1-D8: IN4001, Rectifier, 1 Amp, 50V	GI, ITT
2	-								1		Ea.	D9 - IN746A, Zener, 3.3V, 5%, 500 mW	NPC, Motorola, Siemens, Fairchild, NEC
3	-								1		Ea.	C1 - Aluminum Cap., 10,000 uF, -10+100%, 16V, Axial	United Chemi-Con #16TAL1000 Nichicon, Elna, Illinois Ca
4	-								1		Ea.	C2 - Aluminum Cap., 100 uF, -10+100%, 5V, Axial	United Chemi-Con #25TAL100, Elna, Nichicon, Illinois Ca
5	-							3			Ea.	C4, 5, 6 - Ceramic Cap., 0.1 uF, 20%, 15V, Z5U, Radial	Centralab Type 2DDU, Erie Transcap, Dilectron Type R1 Murata, KCK
6	-								1		Ea.	R1 - Carbon Film, 220 Ohm, 5%, 1/2W	Airco, R-Ohm, ICC
7	-								1		Ea.	C3 - Aluminum Cap., 1000 uF, -10+100%, 25V, Axial	United Chemi-con #35TAL1000 Elna, Nichicon #35TAL1000, Illinois Cap.
8	-								1		Ea.	Power Switch, 3PST Slide	UID #SW432-SD-LO-S-B1-JK
9	-								9		Ft.	Wire, 22 AWG, 7/30 Stranded	American Electric Cable, Teledyne Thermatics

ITEM	REV	PART NUMBER	DWG. SIZE	NUMBER REQUIRED FOR NEXT ASSEMBLY								UNIT OF MEAS.	PART DESCRIPTION	SUGGESTED SOURCE
				1	2	3	4	5	6	7	8			
70		-								1		Ea.	Connector, P/C Header, 5 Pin, to Transformer	Amp #640383-5, Molex KK.156" Series
71		-								1		Ea.	Connector, P/C Header, 6 Pin to Logic Board	Amp #640383-6 Molex KK.156" Series
72		-								1		Ea.	Heatsink for T0-220 Package	Thermalloy #6071B
73		-								2		Ea.	Rivet	Keystone
74		-								1		Ea.	P/C Board, NEMA Grade CEM-1, .062" Thick Single-sided, 12.2 Sq. In., Bare Copper Circuit	
75		2609-9519							1			Ea.	Logic Board Assembly per G.I. Parts List #39-147 Rev. B	
76		-								2		Ea.	R1, 5 - Resistor, Carbon Film, 1K Ohm, 5%, 1/4W	Airco, R-Ohm, ICC
77		-								1		Ea.	R2 - Res., Carbon Film, 47 Ohm, 5%, 1/4W	
78		-								1		Ea.	R4 - Res., Carbon Film, 300 Ohm, 5%, 1/4W	
79		-								2		Ea.	R7, 8 - Res., Carbon Film, 3.3K Ohm, 5%, 1/4W	
80		-								1		Ea.	R9 - Res., Carbon Film, 560 Ohm, 5%, 1/4W	
81		-								1		Ea.	R10 - Res., Carbon Film, 10K Ohm, 5%, 1/4W	
82		-								1		Ea.	R11 - Res., Carbon Film, 100 Ohm, 5%, 1/4W	
83		-								3		Ea.	R13, 14, 23 - Res., Carbon Film, 10 Ohm, 5%, 1/4W	Airco, R-Ohm, ICC

REV	PART NUMBER	DWG. SIZE	NUMBER REQUIRED FOR NEXT ASSEMBLY								UNIT OF MEAS.	PART DESCRIPTION	SUGGESTED SOURCE
			1	2	3	4	5	6	7	8			
-	-						1				Ea.	R16 - Res., Carbon Film, 470 Ohm, 5%, 1/4W	Airco, R-Ohm, ICC
-	-						1				Ea.	R17 - Res., Carbon Film, 2.2K Ohm, 5%, 1/4W	
-	-						1				Ea.	R18 - Res., Carbon Film, 200K Ohm, 5%, 1/4W	
-	-						1				Ea.	R30 - Res., Carbon Film, 150 Ohm, 5%, 1/4W	
-	-						3				Ea.	R3,6,15 - Res., Carbon Film, TBD, 5%, 1/4W	
-	-						3				Ea.	R19,20,21 - Res., Carbon Film, TBD, 5%, 1/4W	
-	-						3				Ea.	R22,26,27 - Res., Carbon Film, TBD, 5%, 1/4W	Airco, R-Ohm, ICC
-	-						3				Ea.	R24,25,28 - Potentiometer, Carbon, TBD, 20%, 1/4W @ 55°C, 270° Rotation, P/C Mount, .65" Dia., Open Construction	Piher PT 15YD, Stackpole, CTS
-	-						1				Ea.	R29 - Potentiometer, Carbon, TBD, 20%, 1/4W @ 55 C, 270° Rotation, P/C Mount, .65" Dia., Open Construction	Piher PT 15YD, Stackpole, CTS
-	-						1				Ea.	C1 - Ceramic Cap., 20pF, 5%, 15V, NPO, Radial	Centralab Type 2DDT, Erie Type 801, Dilectron, Murata, KCK
-	-						20				Ea.	C4-22,24 - Ceramic Cap., 0.1uF, 20%, 15V, Z5U, Radial	Centralab Type 2DDU, Erie Transcap, Dilectron Type RT, Murata, KCK



EXHIBIT C

2609-9993 (Continued)

REV	PART NUMBER	DWG. SIZE	NUMBER REQUIRED FOR NEXT ASSEMBLY								UNIT OF MEAS.	PART DESCRIPTION	SUGGESTED SOURCE
			1	2	3	4	5	6	7	8			
-	-								1		Ea.	C25 - Ceramic Cap., 100pF, 5%, 15V, NPO, Radial	Centralab Type 2DDT, Erie Type 841, Dilectron, Murata KCK
-	-								2		Ea.	C3,26 - Aluminum Cap., 1uf, -10+100%, 15V, Axial	United Chemi-con 16TAL100, Illinois Capacitor, Elna, Nichicon
-	-								3		Ea.	C27,28,30 - Solid Tantalum Cap., 10uF, 20%, 35V, Radial	Sprague 199D, Kemet T392D, Elna, ITT, NEC
-	-								1		Ea.	C31 - Ceramic Cap., .01uF, 20%, 15V, Z5U, Radial	Centralab Type 2DDU, Erie Transcap, Dilectron Type RI, Murata, KCK
-	-								1		Ea.	D1 - Rectifier, IN4001, 1 Amp, 50V	GI, ITT
-	-								2		Ea.	Q1,2 - 2N3906, PNP Small Transistor	Fairchild, National, ITT, NPC, NEC
-	-								1		Ea.	Q3 - 2N3904, NPN Small Signal Trans.	Fairchild, National, ITT, NPC, NEC
-	-								1		Ea.	IC1 - CP1610, uP	GI
-	-								1		Ea.	IC2 - RA-3-9600, RAM	GI
-	-								1		Ea.	IC3 - RO-3-9504, 2KX10 ROM	GI
-	-								1		Ea.	IC4 - AY-3-9600, S IC	GI
-	-								1		Ea.	IC5 - RO-3-9503, 16K ROM	GI
-	-								1		Ea.	IC6 - AY-3-8910, PSG	GI
-	-								1		Ea.	IC9 - RO-3-9502, 2KX10 ROM	GI
-	-								1		Ea.	IC10 - AY-3-8915, Color	GI

REV	PART NUMBER	DWG. SIZE	NUMBER REQUIRED FOR NEXT ASSEMBLY								UNIT OF MEAS.	PART DESCRIPTION	SUGGESTED SOURCE
			1	2	3	4	5	6	7	8			
-	-										Ea.	IC7, 8, 12 - 256x8 RAM	EMM-Semi 3539 UCP
-	-								3		Ea.	IC11 - 7406, Hex Inverter	Fairchild, National, TI, Signetics, NEC
-	-								1		Ea.	IC13 - 74LS08, Quad and Gate	Fairchild, National, TI, Signetics, Motorola
-	-								2		Ea.	IC14,15 - 74LS126, Quad Buffer	Fairchild, National, TI, Signetics, Motorola
-	-								1		Ea.	XTL - Crystal, 3.579545 MHZ, + .01%	Erie, Electro-Dynamics Reeves-Hoffman, Q-Matic
-	-								1		Ea.	C2 - Trimmer Cap., 5.1-50pF, Ceramic, .35" Dia., P/C Mount	Matsushita #ECY-1ZW50X321H Sprague-Goodman #6KD50000
-	-								1		Ea.	RFX - Modulator	Astec #UM1285
-	-								1		Ea.	S1 - SPST Switch	CTS Dwg. C1690A
-	-								1		Ea.	S2 - SPDT Slide Switch, P/C Mount	UID #SL-012-SD-T0-P-B1-EK-CE
-	-								1		Ea.	Connector, P/C Card Edge, 44 Pin	Methode
-	-								6		Ea.	Ferrite Bead, .20" ID, .38" OD, .19"L	Fair-Rite #263000801
-	-								6		Ea.	IC Socket, 40 Pin DIP	T.I. #C8540-01, Augat, Cambio
-	-								1		Ea.	IC Socket, 18 Pin DIP	T.I. #C8518-01, Augat, Cambio
-	-								1		Ea.	IC Socket, 28 Pin DIP	T.I. #C8528-01, Augat, Cambio
-	-								1		Ea.	Connector, 6 Pin - Te P/S Beard	Amp #640428-6 Molex KK.156" Series
-	-								1		Ft.	Wire, 22 AWG, 7/30 Stranded	American Electric Cable, Teledyne Thermatics

REV	PART NUMBER	DWG. SIZE	NUMBER REQUIRED FOR NEXT ASSEMBLY								UNIT OF MEAS.	PART DESCRIPTION	SUGGESTED SOURCE
			1	2	3	4	5	6	7	8			
-										1	Ea.	P/C Board, NEMA Grade CEM-1, .062" Thk., Double-sided, PTH, 48.8 Sq. In Solder Mask One Side, Solder Plated Copper Circuit	



# MATTEL VIDEO GAME SYSTEM

## PARTS LIST

### LOGIC BOARD:

<u>DESIGNATION</u>	<u>P/N</u>	<u>DESCRIPTION</u>	<u>SOURCE</u>
IC7, IC8, IC12	3539	256 X 8 RAM	EMM-Semi
IC11	7406	Hex Inverter	
Q1,Q2	2N39C6	Transistor	
D1	IN40C1	Diode	
R1,R5	1K	1/4 W Resistor 10%	
R2	47 $\Omega$	1/4 W Resistor "	
R3,R6,R15	TBD	1/4 W Resistor "	
R19,R20,R21	TBD	1/4 W Resistor "	
R22,R26,R27	TBD	1/4 W Resistor "	
R4	300 $\Omega$	1/4 W Resistor "	
R7,R8	3.3K	1/4 W Resistor "	
R9	560 $\Omega$	1/4 W Resistor "	
R10	10K	1/2 W Resistor "	
R11	100 $\Omega$	1/4 W Resistor "	
R13,R14,R23	10 $\Omega$	1/4 W Resistor "	
R16	470 $\Omega$	1/4 W Resistor "	
R17	2.2K	1/4 W Resistor "	
R18	20CK	1/4 W Resistor "	
R24,R25,R28	TBD	Trim Potentiometer	
R29			
XTAL	3.579MHz	Crystal	
RFX	Um1285	Modulator	Astec
C1	2C pf	Capacitor	
C2	5-5C pf	Trim cap	
C4-C22,C24	.1 uF	Cap.	
C25	100 pf	Cap.	
C26,C3	1 uf	Cap.	
C27,C28,C3C	10 uf	Tant. Cap.	
C31	.01 uf	Cap.	
S1	SPST-C1690A	Switch	CTS of Elkhart
S2	SPDT	Switch UID Type SL-021-SD-TO-P-B1-EK-CE	
P7		Connector	
P4a	Edge Fingers or	Connector	
P4b	AMP 640099-9	Connector	AMP
J3	640428-2	Connector	AMP
IC 13	74LS08	Quad. and Gate	
IC 14, IC 15	74LS126	Quad. Tri-state buffer	
Q3	2N3904	Transistor	
R30	150 $\Omega$	1/4 W Resistor	
I.C. Sockets		For I.C.1, I.C.2,I.C.3,I.C.4,I.C.5, I.C.6,I.C.7,I.C.8,I.C.9,I.C.10 and I.C.12	

MATTEL VIDEO GAME SYSTEM

Parts List (con't)

POWER SUPPLY BOARD:

<u>DESIGNATION</u>	<u>P/N</u>	<u>DESCRIPTION</u>	<u>SOURCE</u>
S3	SW432-SD-L0-S-B1-JK	Switch	UID/AMF
IC1	uA 7805	5V regulator	
IC2	uA 7812	12V regulator	
D1-D8	IN4D01	Diode	
D9	IN746A	3.3V Zener Diode	
C1	1D000 uf	16V Cap.	Nichicon
C2	100 uf	5V Cap.	
C4,C5,C6	.1 uf	Cap.	
R1	220 	1/2 Watt Resistor	
C3	1000 uf	25V Cap.	
P2	64D383-5	Connector	AMP
P3	64O383-6	Connector	AMP

TRANSFORMER ASSY:

J2                      640428-5              Connector              AMP

HAND CONTROLLER: (2 per system)

J4                      10 Pin Edge or      Connector              AMP  
AMP 640-443-9

FAN ASSY:

J7-J8                      Connector  
Note: Mattel will supply  
information a.s.a.p.

ANTENNA CABLE

ANTENNA SWITCH

MATTEL VIDEO GAME SYSTEM

Parts List (con't)

CONSOLE ASSEMBLY

<u>P/N</u>	<u>DESCRIPTION</u>
0405-0802	Screw (8-18 X 1") Shakeproof Hi-Lo
0405-0822	Screw (6-19 X 1/2") Shakeproof Hi-Lo
2609-9489	Foot - Adhesive 3M SJ-5112
0405-0832	Screw (8-18 X 3/4") Shakeproof Hi-Lo

HAND CONTROLLER ASSEMBLY

0405-0842	Screw (5-20 X 7/16") Shakeproof Hi-Lo
-----------	---------------------------------------



Suggested I.C. Assembly Layout Guides

These guides are suggested for assemblies containing axial lead components to be automatically prepped, sequenced and machine inserted with present available tooling and equipment at the Sylvania, Muncy facility only.

For GTE Sylvania use only.

Rev



SYLVANIA  
ELECTRONIC  
COMPONENTS  
GROUP



Title  
I.C. ASS'Y. LAYOUT GUIDE  
AXIAL LEAD COMPONENTS  
INSERTION MACHINES MUNCY, PA.

Dwg. No. 1-1241

Sheet 1 of 5

## Insertion Machine Capacity

1. Max. insertable area 12" X & 12" Y.
2. Uninsertable areas - Components cannot be inserted within .375 R from any hole that is used for locating P.C. board to machine table. Components leads must be no closer than .180 from P.C. board edges. See Figure 1. Locating holes should always be close to board edge as possible (2 are required).
3. Can insert on lead centers from .250 min. to 1.250 max.
4. Min., Max. insertable component size.
 

a. Body Dia.		.000 min.	.375 max.
b. Body Length		.000 min.	1.000 max.
c. Lead Dia.	Copper	.010 min.	.046 max.
	Steel	.010 min.	.030 max.
	Covar	.010 min.	.030 max.
5. All axial lead components and bare wire that fall within the above size range, are lead taped and meet lead tape Spec. No. A-1234 can be machine inserted.
6. Present sequencer capacity - Components with physical size range between  $\frac{1}{4}$  W RCC7 resistor and  $\frac{1}{2}$  W RC-20 resistors can be sequenced and retaped to be inserted on a maximum of .700 lead centers.
7. Components with similar physical size but different components (or different values or the same component) that number five or less per type, per assembly, are generally sequenced prior to insertion.

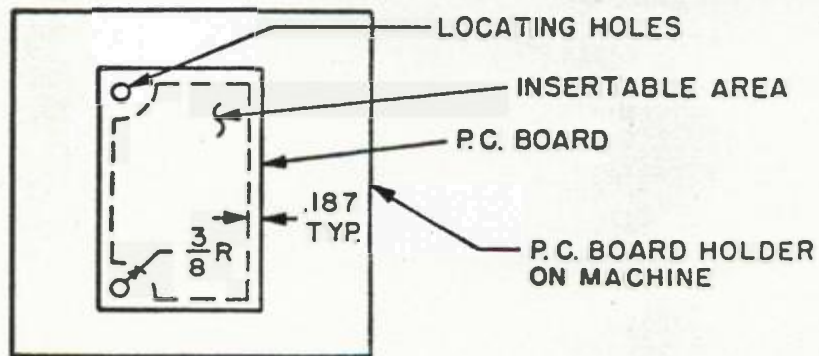

INSERTABLE AREA  
FIG. 1



SYLVANIA  
ELECTRONIC  
COMPONENTS  
GROUP



Title P.C. ASSEMBLY LAYOUT  
GUIDE  
AXIAL LEAD COMPONENTS  
INSERTION MACHINES MUNCY, PA.

Dwg. No. A-1261

Sheet 2 of 5

Rev

If possible, the following ground rules should be followed:

1. Hole Size
  - a. Finished hole size to be .020 to .025 dia. over component lead dia.
2. All axial lead components should be mounted in same axis, same lead centers and have same hole size. Never more than two axis mounting and as few different lead centers and hole sizes as possible.
3. All like components should always be on same lead centers. I.E.  $\frac{1}{4}$  W resistors, .500 centers;  $\frac{1}{2}$  W resistors, .700 centers, etc.
4. Components that are similar in physical size should be layed out on same lead centers and same hole size. Calculate lead centers and hole size using largest component. I.E. DC 7 case diodes,  $\frac{1}{4}$  W resistors would be on .500 lead centers and hole size would be from .015 to .050 diameter. The same would apply for  $\frac{1}{2}$  W resistors and some sizes of capacitors etc., and 1 W resistors and some sizes of capacitors, etc.
5. Component Polarization
  - a. Diodes - Cathode end should be in same direction for all.
  - b. Capacitors - + end should be in same direction for all.
6. Always use maximum component size when calculating lead centers and clearances. These rules are to be used as guides and not restrictions. Components can be inserted into smaller holes, etc.
7. Layout axial lead components on .025, .050, or .100 grid. .050 and .100 preferred.
8. In special cases where these guides and rules are not applicable, each case must be considered separately and usually leads to redesign of insertion tooling and increased tooling costs and turn around time.

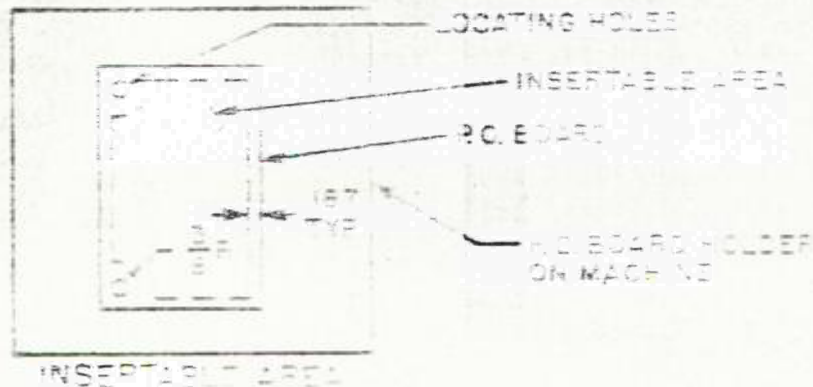

Rev



Title  
P.C. ASS'Y. LAYOUT GUIDE  
AXIAL LEAD COMPONENTS  
INSERTION MACHINES MUNCY, PA.

Dwg. No.  
A-1261  
Sheet 3 of 5



# COMPONENT & TOOL CLEARANCE, AND SOME SUGGESTED LAYOUT PATTERNS FOR AXIAL LEAD COMPONENTS

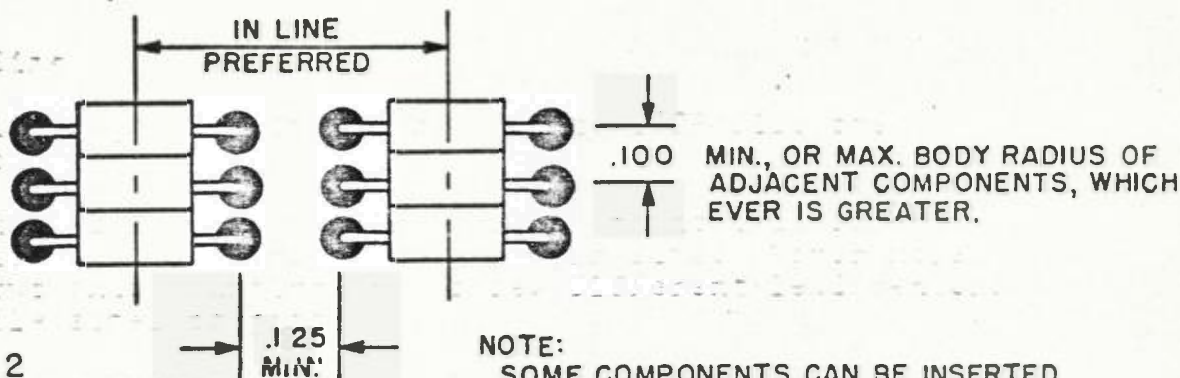

**PATTERN A FIG. 2**  
LAYOUT IN X AND Y AXIS.  
ONE AXIS PER ASSEMBLY  
(PREFERRED)

**NOTE:**  
SOME COMPONENTS CAN BE INSERTED  
BODY TO BODY AS SHOWN.

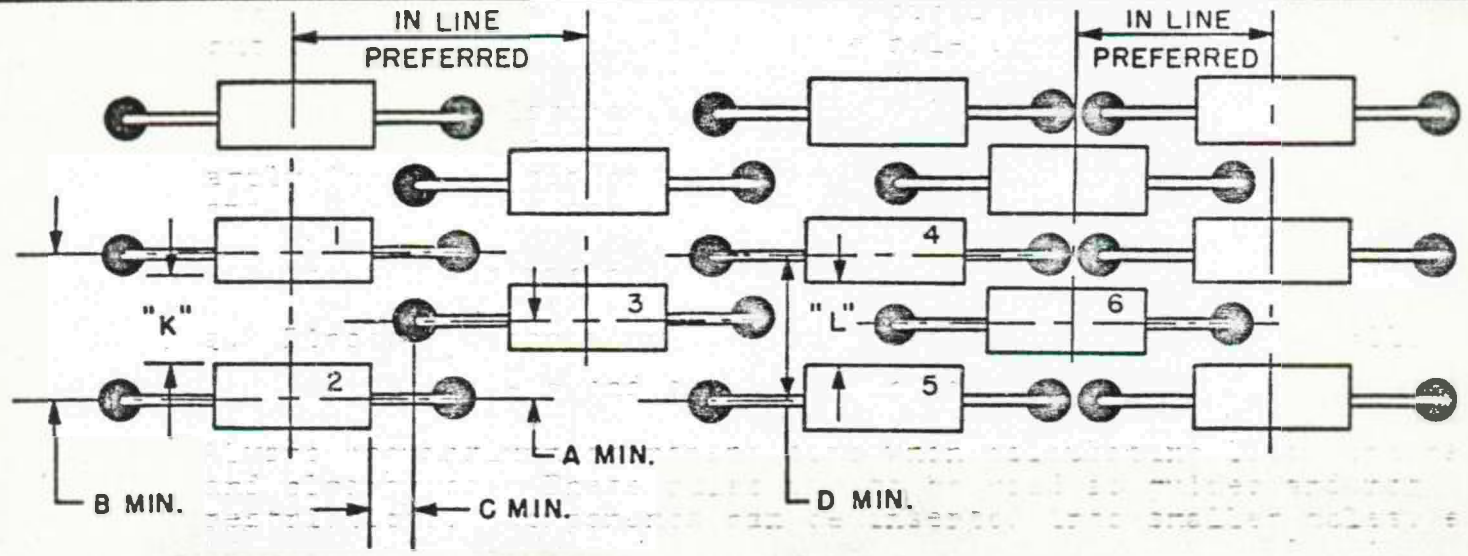

**PATTERN B FIG. 3**  
LEADS INTERLACED

**PATTERN C FIG. 4**  
LEAD & BODY INTERLACED

LAYOUT IN X AND OR Y AXIS  
ON Z AXIS PREFERRED

- A MIN. =  $.070 + 1/2$  WIRE DIAMETER OF COMPONENT NO. 2.
- B MIN. =  $.140 + 1/2$  WIRE DIAMETER OF COMPONENTS NO. 1 & 2 OR  $1/2$  MAX. BODY DIAMETER OF COMPONENTS 1 & 2, WHICH EVER IS GREATER.
- C MIN. =  $.100$  (IF "K" IS OVER  $.140 - .100$  MIN. NOT REQ'D)
- D MIN. =  $.140 + 1/2$  MAX. BODY DIAMETER OF COMPONENTS 4 & 5 ("L" DIMENSION MUST BE  $.140$  MIN.)





AXIAL LEAD COMPONENT SIZE (PREFERRED MIN. & MAX. LEAD CENTERS FOR AUTOMATIC INSERTION) WITH PRESENT AVAILABLE TOOLING & EQUIPMENT AT MUNCY. COMPONENT LEAD CENTERS, ALL AXIAL LEAD TYPES, DIODES, RESISTORS, CAPS, ETC.

STR'S = MAX. A + 2X FROM WIRE DIA. CHART. ROUND OFF UPWARD TO NEAREST .050.

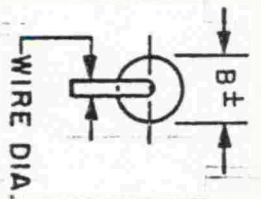
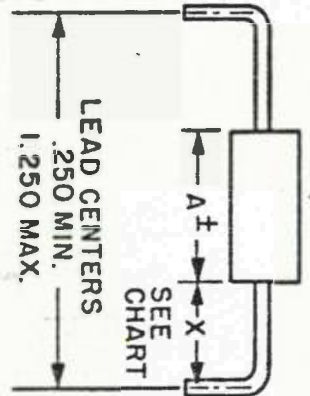

WIRE DIA. CHART

NOM. WIRE DIA.	X MIN.
.015	.050
.020	.075
.025	.085
.030	.090
.040	.115
.050	.120

WHEN WIRE DIAMETER OF COMPONENT FALLS BETWEEN WIRE SIZES LISTED IN CHART, USE NEXT HIGHER WIRE DIAMETER TO OBTAIN "X" MIN.

COMP.	A			B			LEAD DIA.	LEAD CENTERS		
	MIN.	NOM.	MAX.	MIN.	NOM.	MAX.		PREF.	MIN.	MAX.
RES. 1/8 W STYLE RC05	.130	.145	.160	.058	.062	.066	.015 ± .003	300, 500, 700	.250	1.250
DIODE DO-7 CASE SIZE	.230	.265	.300	.085	.096	.107	.020 ± .002	500, 700	.450	1.250
RES. 1/4 W STYLE RC07	.219	.250	.281	.082	.090	.098	.025 ± .002	500, 700	.450	1.250
RES. 1/2 W STYLE RC20	.344	.375	.416	.115	.138	.161	.031 ± .005	700	.600	1.250
RES. 1 W STYLE RC32	.531	.562	.593	.210	.225	.240	.040 ± .005	900	.800	1.250
RES. 2 W STYLE RC42	.648	.688	.728	.300	.318	.336	.045 ± .003	1,000	1,000	1.250

\* COMPONENTS IN THE BODY SIZE RANGE OF 1/4 W RC07 RESISTORS, AND DOT CASE DIODES CAN BE INSERTED IN .400 CENTERS MIN., HOWEVER DUE TO INSUFFICIENT CLEARANCE IN INSIDE FORMERS. COMPONENT SHRINKAGE AND INSERTION TIME IS HIGHER THAN NORMAL.

LEAD CLINCH BELOW

P.C. BOARD

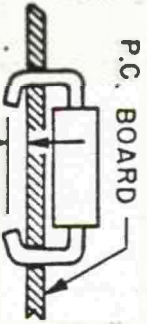

TYPE 1 TIGHT CLINCH

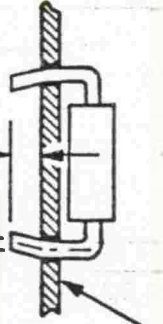

TYPE 2 (PREFERRED) LOOSE CLINCH



No.	Description	Sheet No.	Item No.	Requirements to be Satisfied By:		10 Prototypes		40 Prototypes		G.I. to Prov
				CMD Purch.	G.I. to Provide	CMD	G.I.	CMD Metall to Provide	G.I.	
-5593	Video Game Std. Pack	C2	1 thru 3	N/R	N/R	N/R	N/R	N/R	N/R	N/I
-5592	Toy in Carton	C3	1 thru 5	N/R	N/R	N/R	N/R	N/R	N/R	N/I
	" " "	C3	6 & 7	X	X	X	X	X	X	
-9219	Carton Labeled	C4	1 & 2	G.I.	G.I.	G.I.	G.I.	G.I.	G.I.	
-9581	Video Game	C5	1 & 2	N/R	N/R	N/R	N/R	N/R	N/R	
-9105	Console Assy.	C6	3 thru 7	N/R	N/R	N/R	N/R	N/R	N/R	
"	"	C6	8 & 9	X	X	X	X	X	X	
"	"	C6	10 & 11	X	X	X	X	X	X	
"	"	C6	12	X	X	X	X	X	X	
"	"	C6	13	X	X	X	X	X	X	
"	"	C6	14	X	X	X	X	X	X	
"	"	C7	15	X	X	X	X	X	X	
"	"	C7	16	X	X	X	X	X	X	
"	"	C7	17 & 18	X	X	X	X	X	X	
"	"	C7	19	X	X	X	X	X	X	
"	"	C7	20	X	X	X	X	X	X	
"	"	C7	21	X	X	X	X	X	X	
"	"	C7	22	X	X	X	X	X	X	
-5119	Console Cover-Label	C7	23 & 24	N/R	N/R	N/R	N/R	N/R	N/R	N/I
-6119	Console Cover-Painted	C8	1 thru 3	N/R	N/R	N/R	N/R	N/R	N/R	
-9059	Hand Controller	C9	1	N/R	N/R	N/R	N/R	N/R	N/R	
"	"	C10	2	N/R	N/R	N/R	N/R	N/R	N/R	
"	"	C10	7	X	X	X	X	X	X	
"	"	C10	8	X	X	X	X	X	X	
"	"	C11	1 & 2	X	X	X	X	X	X	

HOWARD CONEN  
 cc: DIMMY BOGART / CLIFF PERRY  
 MAY I PLEASE HAVE YOUR CONCURRENCE THAT THE ABOVE IS MUTUALLY AGREED.  
 THESE ITEMS CORRESPOND WITH THE PARTS LIST IN EXHIBIT C OF OUR PURCHASE AGREEMENT.  
 JOHN ROBERTSON H-5-78

**URGENT**

HOWARD COMEN

SHEET 2 of 3

S. No.	Description	Sheet No.	Item No.	Requirement to be satisfied by:		G.I. to provide	G.I. to provide
				1D Prototype Materiel to provide	4D Prototype Materiel to provide		
				CMD Purch.	CMD Purch.	CMD G.I.	CMD G.I.
9-9059	Hand Controller	C11	3 & 4	X	X		
"	"	C12	1 & 2				
"	"	C13	1 & 2				
9-9559	Per. Supp. Bd. Assy.	C14	1 thru 10	X X	X X		
"	"	C15	11 thru 15				
"	"	C16	16				
6-5519	Logic Bd. Assy.	C17	1 thru 9			X	
"	"	C18	10 thru 17				
"	"	C19	18 thru 25				
"	"	C19	26				
"	"	C19	27 thru 34			X	
"	"	C19	35 thru 37				
"	"	C20	38 thru 43				
"	"	C20	44				
"	"	C20	45 thru 49	X X	X X		
"	"	C21	50				
"	"	C21	51				