

# MATTEL ELECTRONICS®

---

## SUBASSEMBLY SERVICE MANUAL

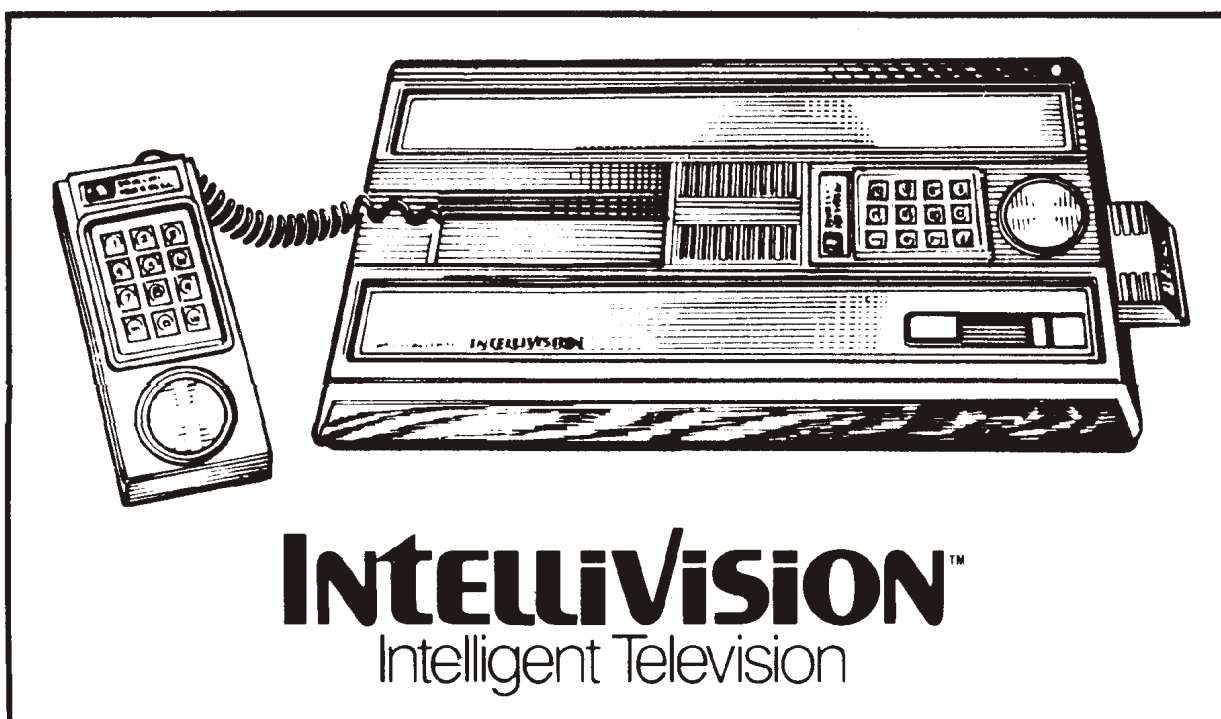

MODEL 2609

---

# MATTEL ELECTRONICS

5150 Rosecrans Avenue  
Hawthorne, California 90250

# TABLE OF CONTENTS

I.	Diagnostic Routine .....	Page 2
II.	Preliminary Checklist .....	Page 5
III.	Troubleshooting .....	Page 6
IV.	Disassembly Instructions	
	A. Console Disassembly .....	Page 10
	B. Logic Board Replacement .....	Page 10
	C. Power Supply Board Replacement .....	Page 12
	D. Transformer Assembly Replacement .....	Page 12
V.	Handcontroller Repair .....	Page 13
VI.	Power Supply Board Repair .....	Page 17
VII.	Parts List .....	Page 18
VIII.	Exploded View of Console Assembly .....	Page 20

## TOOLS AND EQUIPMENT REQUIRED

- Color TV Receiver
- Basic Electronic Hand Tools
- Digital Multimeter (DMM)
- Test Cartridge MTE-201

# DIAGNOSTIC ROUTINE

## SECTION I.

Follow this procedure until you find a malfunction. Then refer to the **PRELIMINARY CHECKLIST** (Section II, page 5 ) and **TROUBLESHOOTING** (Section III, page 6 )

and locate the problem or condition. Follow instructions to correct the fault. Before re-assembling the Master Component, go through this **DIAGNOSTIC ROUTINE** again.

**TURN ALL AUTOMATIC COLOR CIRCUITS TO MANUAL POSITION.**

1. Connect the Master Component to TV, plug in power cord, set the Antenna Switch Box to TV and determine that the set works correctly on broadcast stations. If there is any problem, refer to the **PRELIMINARY CHECKLIST**.
2. Set the Antenna Switch Box to GAME. Set the Channel Select switch of the TV to the designated channel for the Master Component.

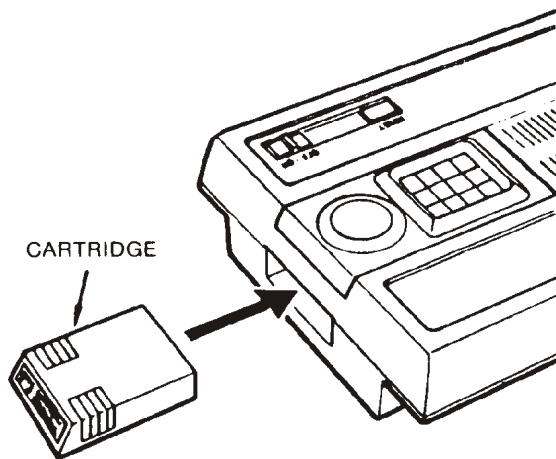

3. Insert the MTE-201 Test Cartridge. Slide the ON/OFF Switch to the ON position and depress the Reset Button on the Master Component. The unit will proceed through a series of checks.

4. At the completion of the above test sequence, the Hand Controller test display will appear as shown in Figure 1.

(a.) Press each key on the Hand Controllers, one at a time and verify that each corresponding test image turns from yellow to white when the appropriate key is depressed. NOTE: The right Hand Controller will affect the left test image and vice versa.

(b.) Press the top side buttons on the Hand Controllers one at a time. Make sure that the pair of Fs change from yellow to white.

(c.) Press each lower side button on the Hand Controllers one at a time and see that the letters L and R change from yellow to white.

(d.) Depress the directional disc on each Hand Controller and a white arrow will appear in the black circle. As the directional disc is rotated, the arrow will rotate. Check to see that the arrow points in 16 different directions.

(e.) Check the row of colored boxes for similarity as listed in Figure 1.

Next, depress the digit keys 1 and 9 simultaneously on either Hand Controller and the test sequence will proceed to the sound checks.

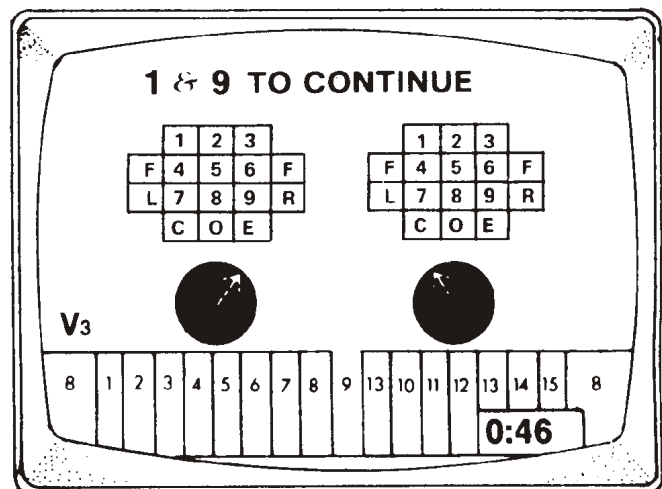

COLOR CODE:	1. Black	6. Light Green	11. Brown
	2. Blue	7. Yellow	12. Magenta
	3. Red	8. White	13. Light Blue
	4. Tan	9. Gray	14. Yellow/Green
	5. Dark Green	10. Orange	15. Purple

Figure 1 Hand Controller Test Pattern

5. Verify the following sequence of sounds is heard:

- (a.) A low frequency rumble.
- (b.) A high note stepping down through five octaves (repeated three times).
- (c.) Random noise (hissing) starting at a high volume and diminishing slightly.
- (d.) A single tone, starting at a high volume and diminishing slowly.
- (e.) Two gunshots, one at normal volume, the second at half volume.

If all of these sounds are heard as described, depress the CLEAR key on either Hand Controller. In the event any part of the test has failed, depress the ENTER key. (NOTE: The test sequence cannot be advanced if the CLEAR or ENTER key is depressed while sounds are being generated.)

6. The next segment of the test presents a series of patterns, ending with the pattern illustrated in Figure 2. Check colors in the test pattern against Figure 2 for similarity and definition. If test pattern accuracy is satisfactory, press the CLEAR key. If it is unsatisfactory, press the ENTER key.

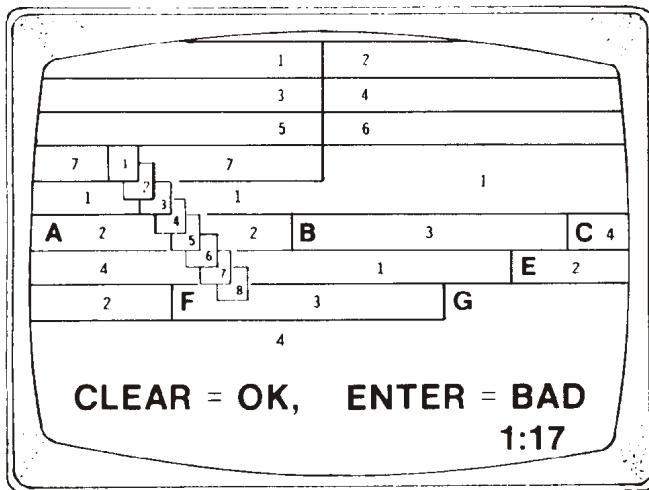

- COLOR CODE:
- |               |                |                  |
|---------------|----------------|------------------|
| 1. Black      | 6. Light Green | 11. Brown        |
| 2. Blue       | 7. Yellow      | 12. Magenta      |
| 3. Red        | 8. White       | 13. Light Blue   |
| 4. Tan        | 9. Gray        | 14. Yellow/Green |
| 5. Dark Green | 10. Orange     | 15. Purple       |

Figure 2

7. The next portion of the test sequence is a pattern of colored blocks with the two larger blocks alternating with the words MODE TWO, as illustrated in Figure 3. Check colors in test pattern against Figure 3 for similarity and definition. If test pattern accuracy is satisfactory, press the CLEAR key. If it is unsatisfactory, press the ENTER key.

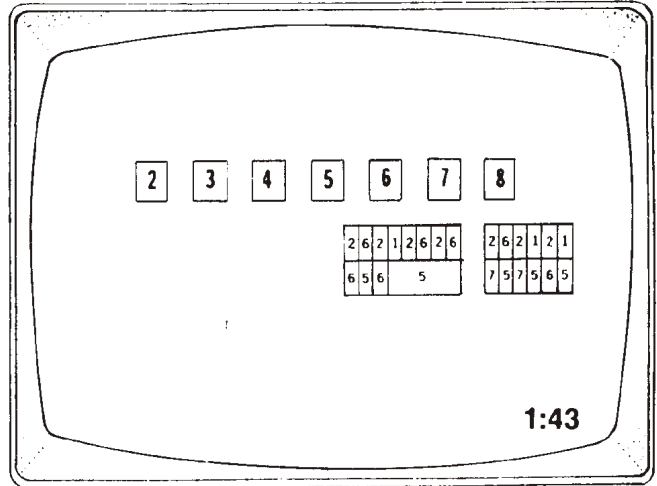

- COLOR CODE:
- |               |                |                  |
|---------------|----------------|------------------|
| 1. Black      | 6. Light Green | 11. Brown        |
| 2. Blue       | 7. Yellow      | 12. Magenta      |
| 3. Red        | 8. White       | 13. Light Blue   |
| 4. Tan        | 9. Gray        | 14. Yellow/Green |
| 5. Dark Green | 10. Orange     | 15. Purple       |

Figure 3

8. The last test alternately flashes the patterns "F/B" and "VIS." Press CLEAR for pass or ENTER for fail.

If no failure has been detected, the title page for Baseball will appear; this indicates the Master Component has passed all the automatic and

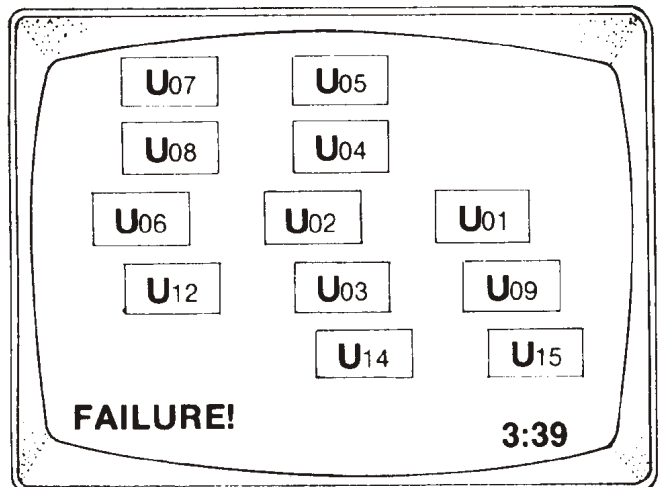

Figure 4

operator tests. In the event a failure has been detected, instead of the title page being displayed, a display as shown in Figure 4 will appear or the test will indicate "Failure at Test \_\_\_" followed by a letter between A and Z. If either is displayed, refer to Section III-6, Page 9.

**9.** The next test is an actual game check to confirm the functional operation of the Master Component. When the title page for Baseball is displayed, follow the instructions provided with the MTE-201 Test Cartridge to play ½ inning of Baseball.

Upon successful completion of the baseball game, the test routine for the Master Component is complete.

**10.** This Diagnostic Routine can be repeated—from the beginning—any time. Just press the RESET button.

# PRELIMINARY CHECKLIST

## SECTION II:

Before you refer to the TROUBLESHOOTING Section which follows, look at this list of pos-

sible quick solutions. Then, if any problem persists, you should be able to find it in TROUBLESHOOTING.

Turn ON/OFF Switch to ON and press RESET. With the Test Cartridge still inserted, go through the DIAGNOSTIC ROUTINE and check for these problems:

PROBLEM	POSSIBLE SOLUTION
SCREEN IS BLANK	— Press any key on either Hand Controller key pad to recover picture.
NO TV PROGRAMS	— Check connection of cable from Antenna Switch Box to antenna connector on TV. — Make sure Antenna Switch Box is set at TV. — Make sure that coax cable is attached.
BUZZING OR DISTORTED SOUND	— Adjust TV fine tuning controls. — If there is broadcast interference from a strong signal, disconnect antenna coax from Antenna Switch Box. (This must be reconnected for broadcast viewing.)
NO GAME SOUND EFFECTS	— Turn up TV volume control. — Adjust fine tuning.
WHITE-GRAY SCREEN OR SCREEN IS ONE COLOR	— Make sure cartridge is properly inserted.
SNOWY SCREEN (NO RF CARRIER)	— Make sure: — TV tuner is set on the proper channel. — Antenna Switch Box is set at GAME. — Game coax cable is properly plugged into Antenna Switch Box. — Power switch is ON. — Check all connections, including power plug.
TEST IMAGE NOT DISTINCT, AS IF FROM WEAK SIGNAL	— Adjust fine tuning, brightness, and contrast controls. — Check connections at Antenna Switch Box, TV antenna connector, and game output connector.
TEST IMAGE BLURRED, WOBBLY, OR NO COLOR	— Adjust fine tuning, brightness, contrast, and color. — If there is broadcast interference from a strong signal, disconnect antenna cable from Antenna Switch Box. (This must be reconnected for broadcast viewing.)

# TROUBLESHOOTING

## SECTION III

Find the Phrase in the left-hand column below which best describes the malfunction or condition you encountered. Follow each step of

the related instructions. Then repeat the entire **DIAGNOSTIC ROUTINE** as described in Section I.

### MALFUNCTION/CONDITION

1. NO TV PROGRAMS, NO INTELLIVISION TEST PATTERNS, SNOWY OR WHITE-GRAY SCREEN.

### SERVICE INSTRUCTIONS

- 1.0 Verify that TV receiver works.
- 1.1 Disconnect Antenna Switch Box assembly and replace with a known good unit.
- 1.2 Disconnect Antenna Cable and replace with a good one.
- 1.3 Disassemble Master Component (See Section IV-A, Page 10).
- 1.4 Unplug Master Component and check ON/OFF switch for continuity.
- 1.5 When the Component is disassembled, perform the following test procedure:
  - (a) Carefully remove 5-pin ribbon connector and 2-pin plug from the Power Supply Board (see Figure 5, Page 8).
  - (b) Plug in Master Component and turn ON/OFF Switch to ON.
  - (c) Connect negative probe of voltmeter to Ground Test Point on the Power Supply Board. Connect positive probe to +5 Volt Test Point. Refer to Figure 5. Meter should read 4.85-5.15 VDC.
  - (d) With negative probe still on Ground, connect positive probe to +12 Volt Test Point. Meter should read 11.64-12.36 VDC.
  - (e) With negative probe still on Ground, connect positive probe to +16 Volt Test Point. Meter should read at least +16 VDC.
  - (f) Connect positive probe to ground and negative probe to -2.1 Volt Test Point. Meter should read 1.95-2.25 VDC.
  - (g) Connect negative probe to ground and positive probe to +5.65 volt connector pin. Meter should read at least **12 VDC**.

## 1. CONTINUED .....

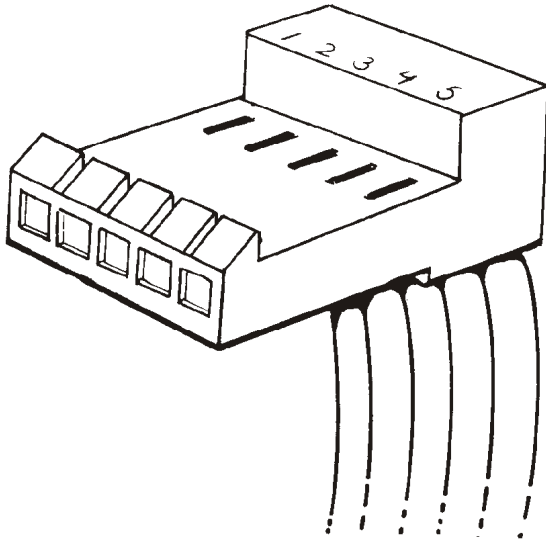

**(h)** Turn power off. Reconnect 5-pin ribbon cable and 2-pin plug. Turn power on and remeasure voltage at +5.65 volt connector pin. Meter should read 5.45 - 5.85 VDC. If voltage is not within limits, turn off power and measure resistance of R2 (Figure 5). If OK, replace logic board. If not OK, troubleshoot power supply board.

**(i)** If voltages are present, replace the Logic Board (See Section IV-B, Page 10).

**(j)** If the above voltages are not present, remove the 5-pin Transformer Connector from the Power Supply Board. DO NOT push meter probes into socket holes to measure voltage or socket will be damaged. Touch meter probes to the slide contacts visible on the top of the socket to measure voltages. Set meter on AC, and check for these voltages:

- With probes in holes #3 and #1, meter should read 7.6 - 9.4 VAC RMS.
- With probes in holes #3 and #2, meter should read 7.6 - 9.4 VAC RMS.
- With probes in holes #4 and #5, meter should read 15.3 - 18.7 VAC RMS.

**(k)** If all voltages read as described in Step (j), repair or replace the Power Supply Board (See Section IV-C, Page 12).

**(l)** If any voltages differ from the values in Step (j), replace the Transformer Assembly (See Section IV-D, Page 12).

Verify that replacement of the Transformer Assembly and/or Power Supply Board has corrected any supply voltage problem by repeating steps (b) through (h) above.

If voltages are correct and a known-good Logic Board has been installed but symptoms persist, the fault could be with Power Connector J3 on the Power Supply Board.

DO NOT CHECK SUPPLY  
VOLTAGES AT THE J3 RIBBON  
CONNECTOR AS METER PROBES  
COULD DAMAGE CONNECTOR  
PINS. CHECK VOLTAGES AT  
THE TEST POINTS SHOWN IN  
FIGURE 5.



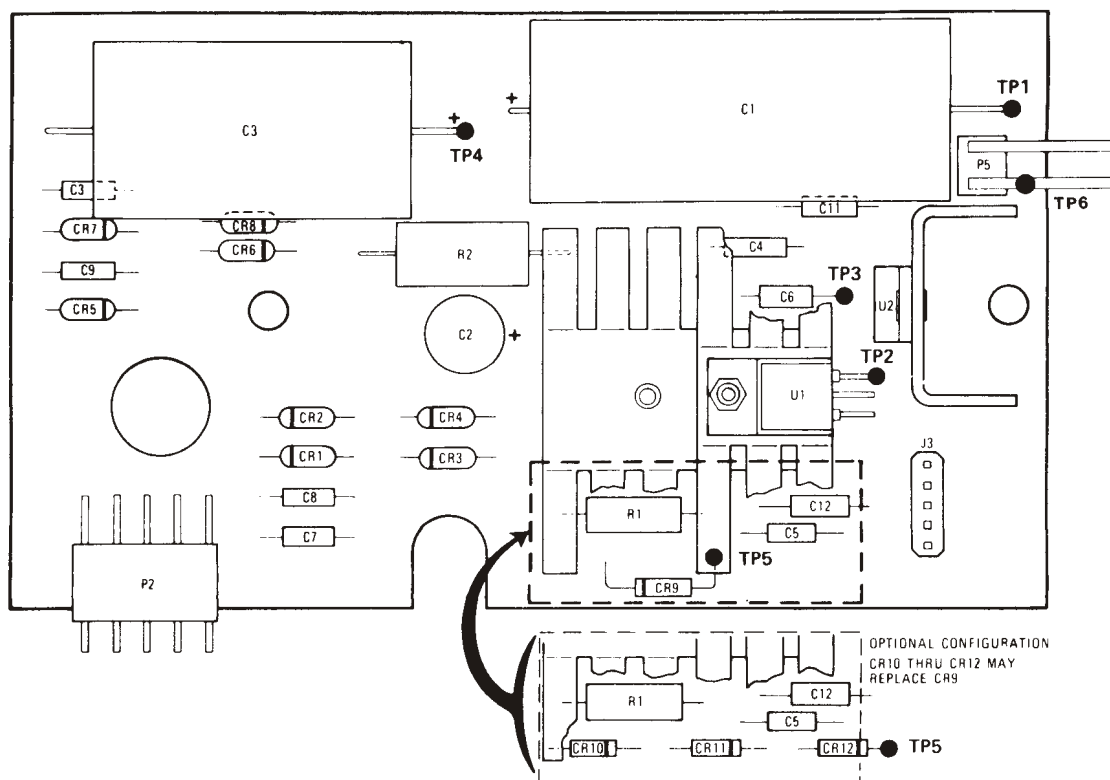

Figure 5 Test Points Location Diagram

TP-1	.....	GROUND
TP-2	.....	+5V DC TEST
TP-3	.....	+12V DC TEST
TP-4	.....	+16V DC TEST (Non-Regulated)
TP-5	.....	-2.1V DC TEST (Early Production -3.3V)
TP-6	.....	+5.65V DC (Non-Regulated)

#### MALFUNCTION/CONDITION

2. TEST PATTERNS OR GAME PICTURE JUMBLED, OR UNWANTED CHARACTERS ON SCREEN
3. NO SOUND OR GARBLED SOUND
4. BAD ON/OFF SWITCH
5. TEST CARTRIDGE DOES NOT RESPOND TO HAND-CONTROLLER(S)

#### SERVICE INSTRUCTIONS

- 2.1 Follow Procedure 1.5 (a) thru (l) (See Section III-I, Page 6).
- 3.1 Make sure that TV volume is turned up, and that sounds on broadcast stations are good.
- 3.2 Replace Logic Board (See Section IV-B, Page 10).
- 4.1 Replace Transformer Assembly (See Section IV-D, Page 12).
- 5.1 Replace Hand Controllers (See Section IV-B, Page 10).
- 5.2 If Procedure 5.1 doesn't cure the problem, replace Logic Board (See Section IV-B, Page 10).

<b>MALFUNCTION/CONDITION</b>	<b>SERVICE INSTRUCTIONS</b>
<p>6. TEST INDICATES FAILURE IN PARTS OTHER THAN HAND-CONTROLLERS</p> <p>7. NO APPARENT FAILURE — ALL TESTS PASS</p>	<p><b>6.1 Replace Logic Board (See Section IV-B, Page 10).</b></p> <p>7.1 Insert customer's game cartridge in Component and watch for: mistakes in lettering on title picture, jumbled play-field, or unwanted characters. Test with a known-good Game Cartridge. If problems continue, follow Procedure 1.5 (a) thru (I), Section III-1, Page 6. If problems do <b>not</b> appear, customer's cartridge is defective.</p> <p><b>7.2 NOTE: FOLLOW THIS STEP FOR SHOP SERVICE ONLY:</b></p>

Insert MTE-201 Test Cartridge and press Reset. Run the diagnostic tests until the television screen shows the title page for Baseball (the screen will show "Mattel Electronics presents Baseball"). DO NOT touch any keys or switches. Disconnect or turn off the TV set and let the Master Component burn-in for 90 minutes.

After 90 minutes, re-connect or turn on the television set. The title page should be seen on the television screen. Press Reset and run the diagnostic tests and play ½ inning of baseball. If the results again show no failures, the Master Component is considered to be GOOD.

### **IMPORTANT REMINDER**

After completing any TROUBLESHOOTING or DISASSEMBLY, **always** go through the DIAGNOSTIC ROUTINE described in Section I before reassembling the unit.

<p>8. TEST CARTRIDGE CHECK</p>	<p><b>8.1</b> Should you suspect the MTE-201 Test Cartridge to be defective, it can be tested as follows: Depress keys 2 and 8 simultaneously when the Hand Controller Test is displayed (Figure 1) and a checksum will be displayed. The display should look like this:</p>
--------------------------------	--

CART CHECKSUM LO=  
00002371677

CART CHECKSUM HI=  
00003372642

If any other numbers appear or the numbers differ, it indicates a failure in the test cartridge and another cartridge should be used.

# DISASSEMBLY INSTRUCTIONS

## SECTION IV:

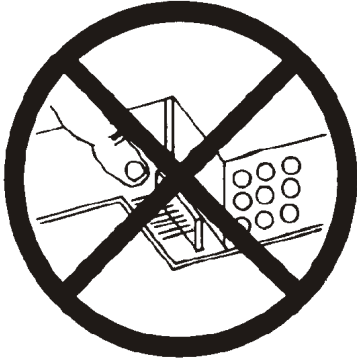

### WARNING:

Use care when connecting or disconnecting hand controller connectors from logic board. Do not touch the pins on the logic board as static discharge may damage internal circuitry.

### A. CONSOLE DISASSEMBLY

**Be sure unit is unplugged before disassembly.**

- (1) Turn Console upside down and loosen (6) Phillips head screws.
- (2) Turn Console right-side up, allow the (6) screws to fall out, then pull upon the ON/OFF glamour cap to remove. **DO NOT remove the RESET button.**
- (3) Remove top case and slip Hand Controllers through openings.

**NOTE:** When re-assembling Console, replace Hand Controller tray first. Refer to Figure 6 for position of Controller wires.

### B. LOGIC BOARD OR HAND CONTROLLERS REPLACEMENT

- (1) Follow Console Disassembly procedure above — steps (1) through (3).
- (2) Remove (6) screws from Hand Controller tray, and remove the tray.
- (3) Disconnect Switch Box cable from console and remove any cartridge.
- (4) Carefully disconnect the 5-pin ribbon connector and the 2-pin connector from Power Supply Board.

**The Logic Board and metal shields go together.  
DO NOT try to separate them.**

- (5) Lift Logic Board straight up. Carefully disconnect Hand Controllers (if a problem exists in just one Controller, it is not necessary to remove both of them). When replacing Connectors to Logic Board, the Connector must be inserted according to the illustration in Figure 6, page 11.

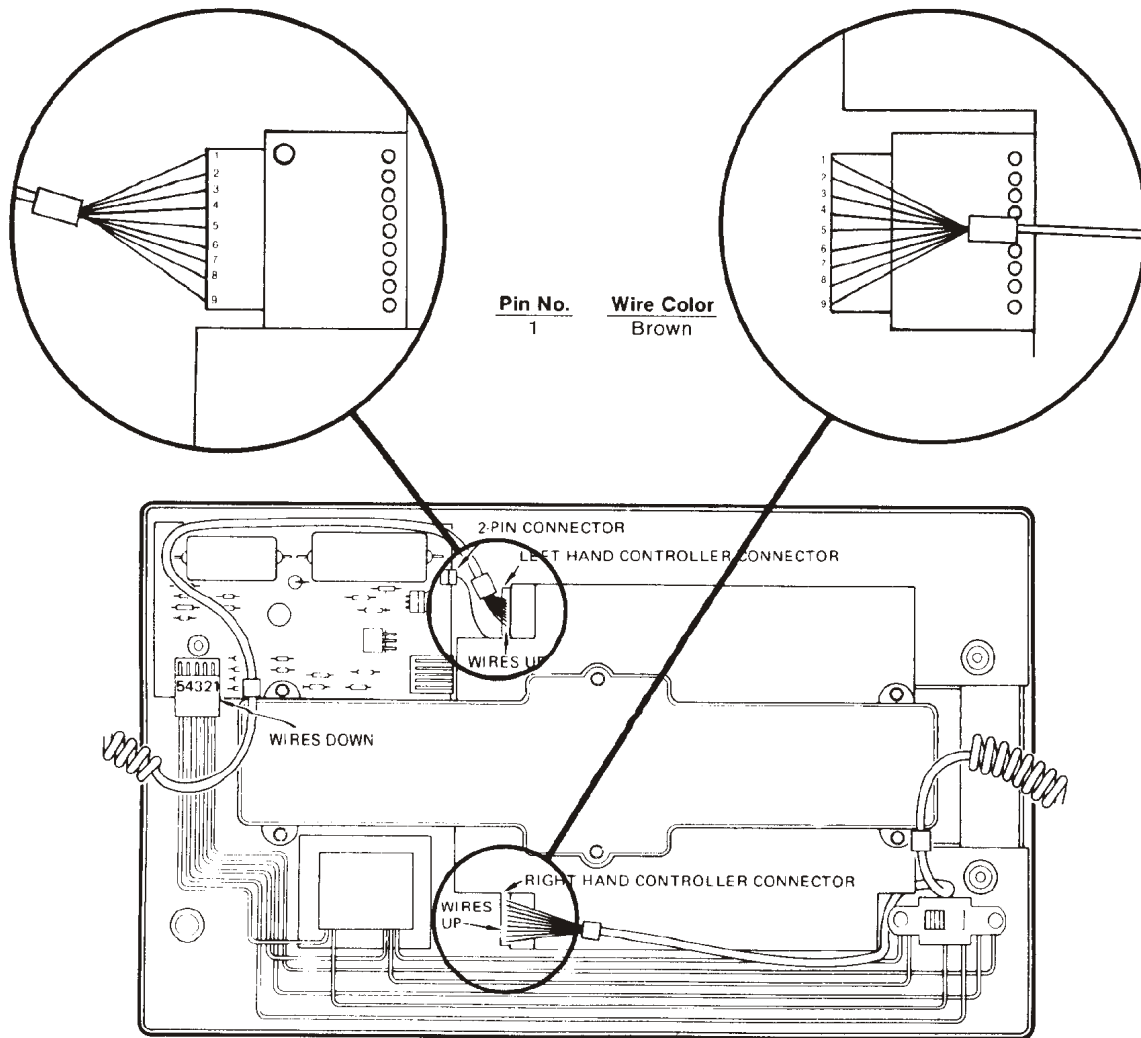

Figure 6

### C. POWER SUPPLY BOARD REPLACEMENT

- (1) Remove (6) screws from Hand Controller tray. Remove the tray.
- (2) Carefully disconnect the 5-pin ribbon connector, the 2-pin connector and the 5-pin transformer connector from the Power Supply Board.
- (3) Remove (2) screws from the Power Supply Board and replace the Board (but not the Hand Controller tray — yet).

**★ SAFETY PRECAUTION ★**

FIBER INSULATOR(S) MUST BE PROPERLY REPLACED UNDER POWER SUPPLY BOARD. IF UNIT WAS EQUIPPED WITH TWO INSULATORS, BE SURE THAT BOTH ARE REPLACED.

### D. TRANSFORMER ASSEMBLY REPLACEMENT

**NOTE:** Unplug Master Component before attempting parts replacement.

- (1) Disconnect 5-pin Ribbon Connector from Logic and Power Supply Boards.
- (2) Unscrew the Hand Controller tray and Power Supply Board.
- (3) Remove the Power Supply Board and any insulation underneath it.
- (4) Remove the 5-pin Transformer connector from Power Supply Board.
- (5) Remove (4) screws, 2 from the Transformer and 2 from the ON/OFF switch.
- (6) Replace the Transformer Assembly, reversing the above steps.

**IMPORTANT REMINDER**

After completing any TROUBLESHOOTING or DISASSEMBLY, **always** go through the entire DIAGNOSTIC routine described in Section I before reassembling the unit.

# HAND CONTROLLER REPAIR

**IMPORTANT:** Make sure foreign material . . . dirt, dust, etc., does not come in contact with the circuit matrix or other plastic parts.

**Unplug Master Component from power source. Disconnect switch box cable.**

**(a.) Disassembly:** Turn the Hand Controller upside down on a flat surface and hold it firmly. Use a Phillips-head screw driver to remove the 4 screws. Remove bottom screws first. Set all 4 screws aside in a safe place. Refer to Figure 7 below.

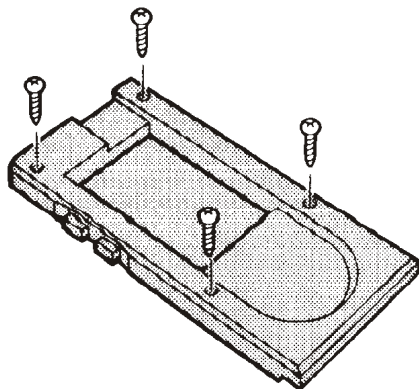

Figure 7

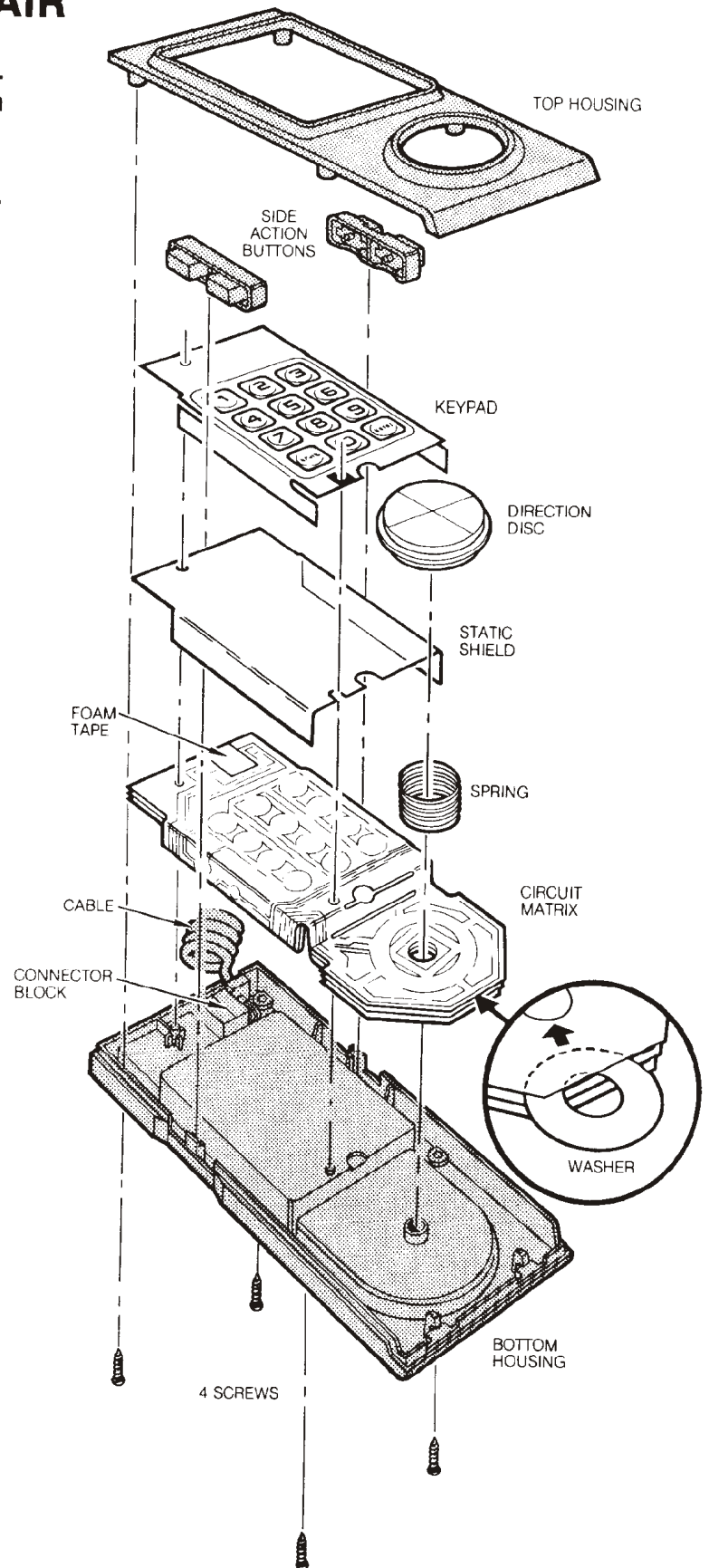

Figure 8

(1) While holding the top and bottom housings together, turn the Hand Controller right side up. Set it back on a flat surface. (See Figure 9.)

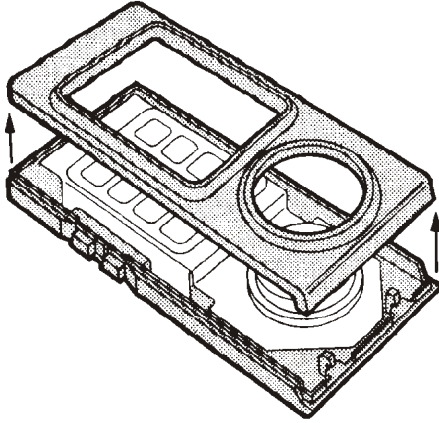

Figure 9

(2) Carefully lift the top off and set it aside. Hold the number keypad and the Gold Directional Disc in place with one hand.

(3) Remove the Gold Directional Disc and Spring.

(4) Remove the Action Buttons from both sides.

(5) Remove the static shield and the circuit matrix from the lower housing. (See Figure 8.)

(6) Remove the cable from the lower housing by lifting the cable strain relief up and out of the housing. Pry up the cable connector block from its mount in the housing. **CAUTION:** Be careful not to touch or bend the metal prongs. (See Figures 10 and 11.)

(7) If bottom housing has a raised lip around the directional disc guidepost, replace the bottom housing.

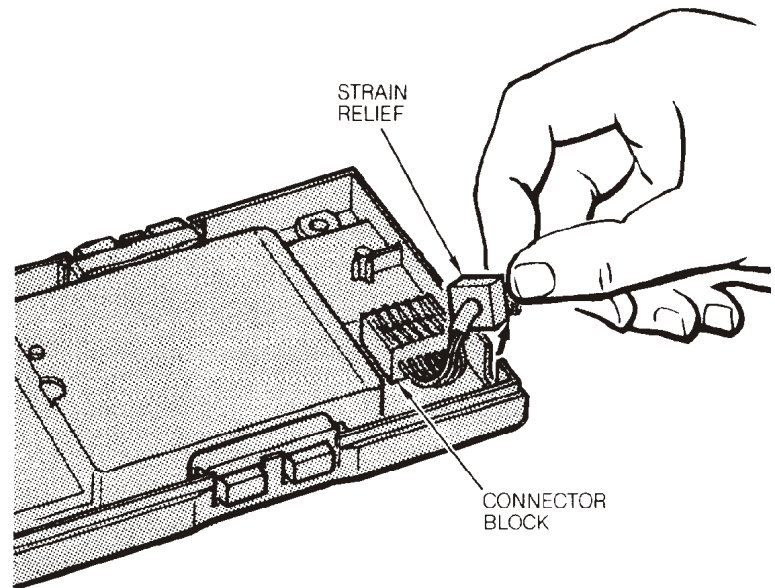

Figure 10

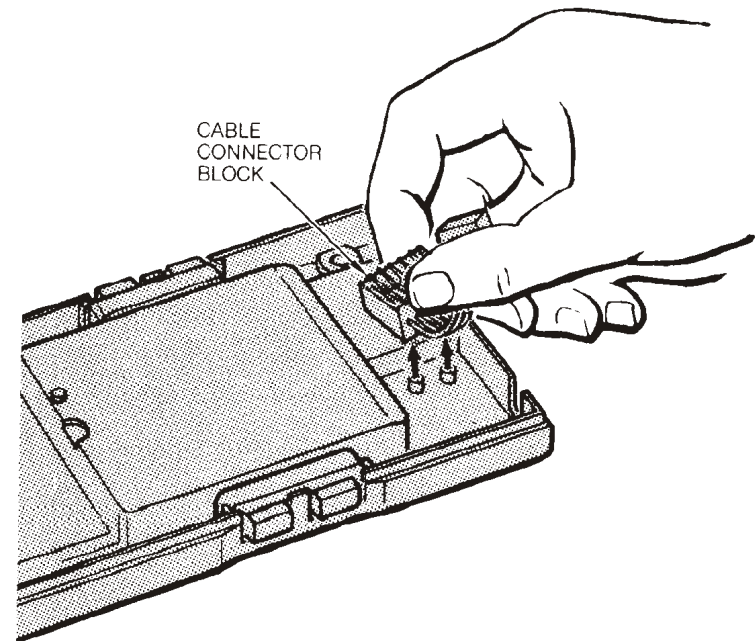

Figure 11



**(b.) Component Replacement and Reassembly.**

(1) Place the replacement cable assembly in the lower housing as shown in Figures 10 and 11.

(2) Make sure the replacement circuit matrix is correctly folded as shown in Figure 12 below.

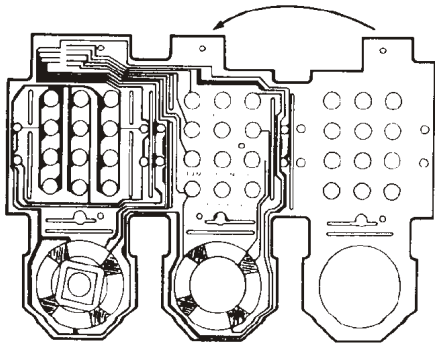

**CAUTION: AVOID EXCESSIVE FOLDING OR HANDLING OF THE CIRCUIT MATRIX.**

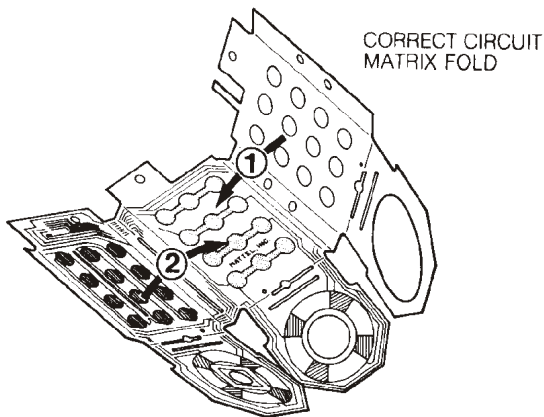

Figure 12

Apply foam tape (2609-6159) to circuit matrix as required. Refer to Figure 13. Install the circuit matrix as shown in Figure 8 and make sure it fits snugly over the top and bottom posts.

Foam tape is to be applied directly to the folded circuit matrix. Tape is to be captured between matrix and domed legend, and pressed to secure its position. Refer to Figure 13.

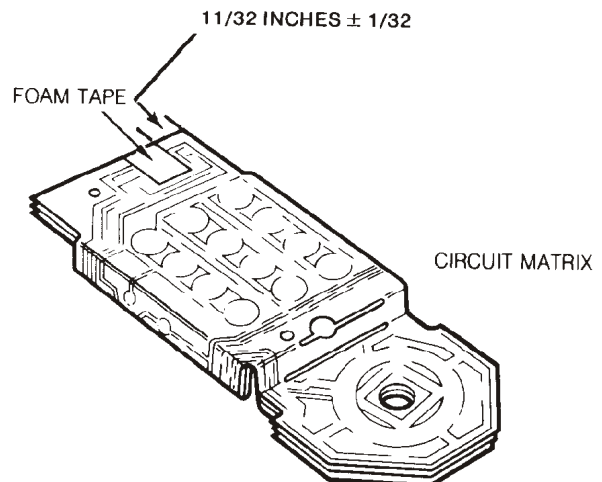

Figure 13 Foam Tape Replacement



**(3)** Install the static shield over the folded circuit matrix, making sure the posts go through both sets of holes (shield and matrix). Refer to Figure 8. Hold the matrix and shield in place with fingers.

**(4)** Install the keypad over the matrix and static shield. Again make sure both posts go through keypad holes.

**(5)** Check that the components are correctly installed. Place the washer under the top layers of the circuit matrix and over the directional disc post as shown in Figure 8.

**(6)** Press action buttons firmly in position. The scalloped edge should be on the **BOTTOM, FACING INWARD**. The buttons will only fit one way. Refer to Figure 14 below.

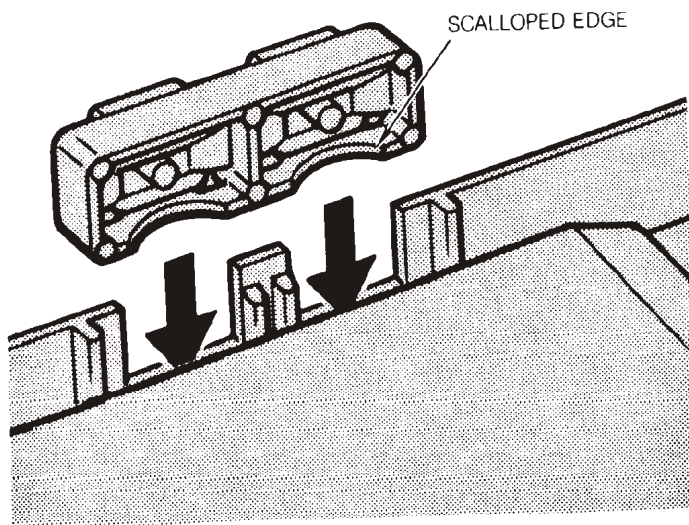

Figure 14

**(7)** Mount the spring and Directional Disc. Refer to Figure 8.

**(8)** Before reinstalling the top housing, make sure the circuit matrix and keypad are securely in place so that the top and bottom holes fit over the small brown posts. See Figure 15.

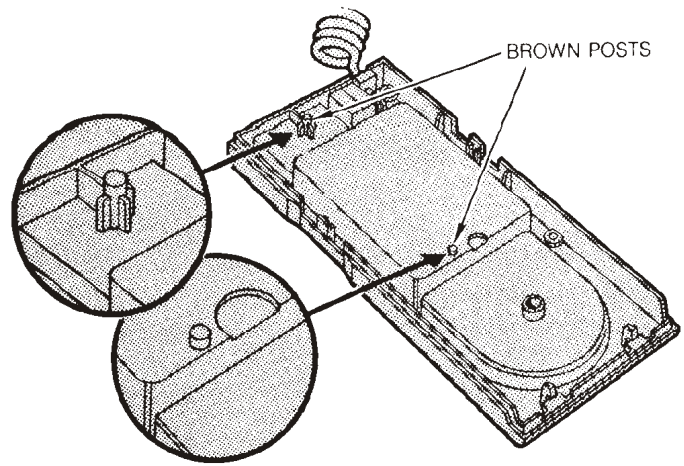

Figure 15

**(9)** Install the top housing. Hold the top and bottom securely together while you turn the Hand Controller over. Replace the 4 screws, **TOP SCREWS FIRST**. Tighten until firmly in place. This is important to make all the circuit connections. **DO NOT OVERTIGHTEN.**

**(10)** Connect the Hand Controller to a working M/C and using the MTE-201 Test Cartridge, check for proper operation.



# PARTS LIST

REF. NO.	DESCRIPTION	PART NO.
①	Logic Board Assembly .....	2609-9169
②	Power Supply Board Assembly .....	2609-9539
C1	Capacitor, 10,000uF 16V Elect. ....	0085-0005
C2	Capacitor, 100uF 16V Elect. ....	0085-0004
C3	Capacitor, 2200uF 25V Elect. ....	0085-0006
C4 - C10	Capacitor, 0.1uF 25V .....	0085-1510
C11, C12	Capacitor, 0.22uF 25V .....	0085-1410
R1	Resistor, 220 ohm ½W 5% .....	0095-0576
R2	Resistor, 12 ohm 3W 10% WW .....	0089-0928
CR1 - CR8	Diode, IN4001 .....	0099-1030
CR9	Diode, Zener IN746 .....	0086-0425
CR10 - CR12	Diode, IN4001 .....	0099-1030
P2	Plug, 5 pin .....	2609-9239
J3	Jack, 5 pin .....	0099-0390
P5	Plug, 2 pin .....	0089-0007
U1	I.C. uA 7805 .....	0098-2130
	Small Heatsink for U1 .....	0099-0310
	Large Heatsink for U1 .....	0089-0606
U2	I.C. LM 340T12 .....	0098-2140
	Heatsink for U2 .....	0099-1570
③	Transformer ON/OFF Switch Assembly .....	2609-9629
④	ON/OFF Switch .....	2609-9559
⑤	Tray .....	2609-2149

REF. NO.	DESCRIPTION	PART NO.
6	Top Housing Assembly .....	2609-9719
7	Inlay, Plain .....	2609-4529
8	Spring, Reset .....	2609-4269
9	Button Reset .....	2609-2129
10	Glamor Cap, ON/OFF Switch .....	2609-2139
11	Inlay, Control .....	2609-4519
12	Pushnut Fastener .....	0405-0852
13	Foot .....	2609-9489
14	Handcontroller Assembly .....	2609-9059
	Top Housing .....	2609-9069
	Direction Disc w/Inlay .....	2609-9089
	Spring, Direction Disc .....	2609-4279
	Side Action Button .....	2609-2099
	Keypad (Domed Legend) .....	2609-6379
	Static Shield .....	2609-4549
	Circuit Matrix .....	2609-9589
	Foam Tape .....	2609-6159
	Mylar Washer .....	2609-4019
	Cable Assembly .....	2609-9579
	Bottom Housing .....	2609-2059
	Screw, 5-20 x 7/16 in. ....	0405-0842
	Antenna Switch Box .....	2609-9609
	R.F. Cable .....	2609-9599

# EXPLODED VIEW

Unit must be unplugged prior to attempting disassembly and/or replacement of parts.

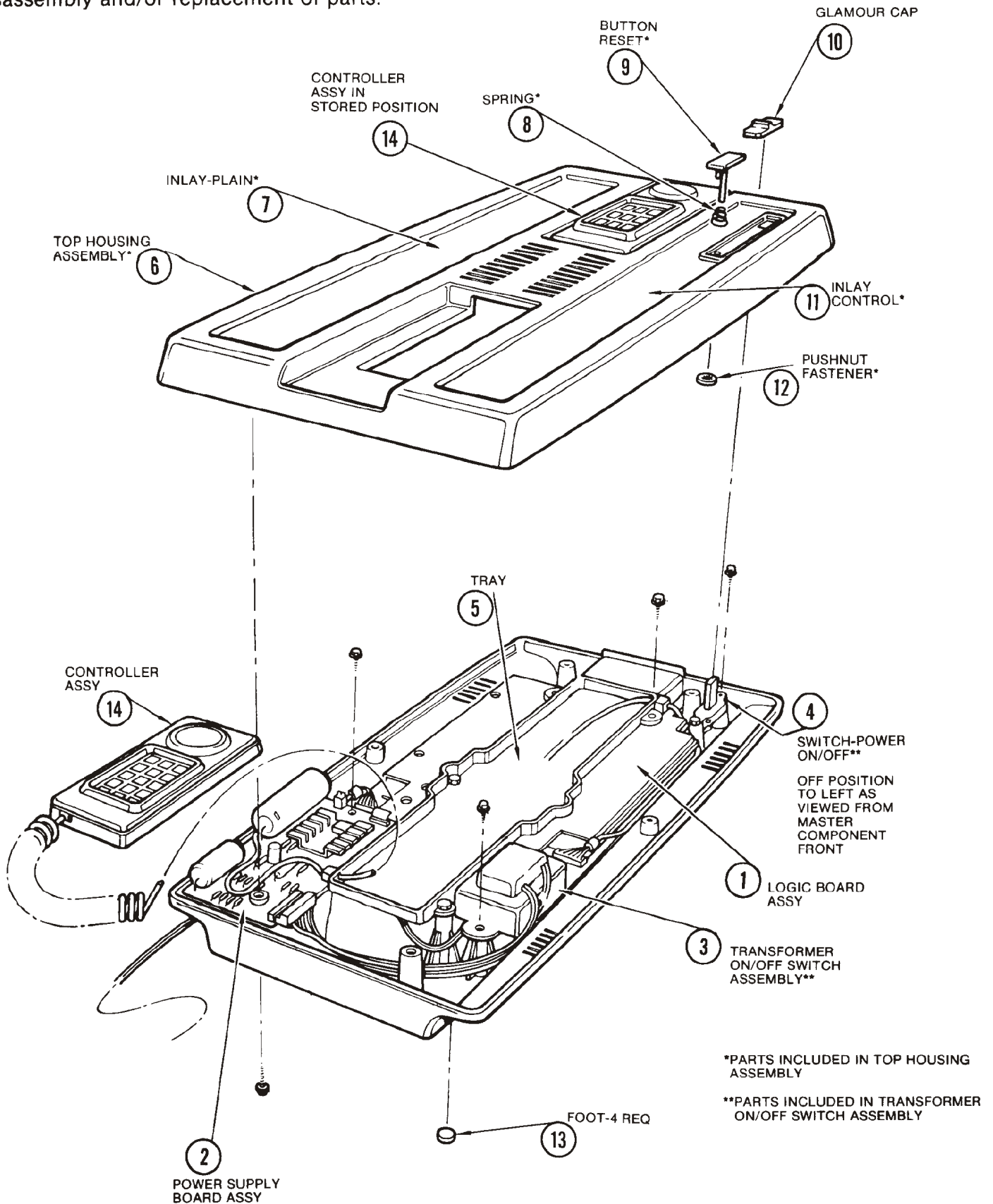

EXPLODED VIEW . . . . . Console Assembly